

Collet ISO 10897 B 25 (formerly DIN 6388)

Taper ratio 1:10

Design:

- Hardened and ground
- Slit 12 times
- Clamping tolerance 0.5 mm (for example, a collet with a nominal dimension $d = 25$ mm clamps a shank \varnothing of 24.5 to 25 mm)

Application:

- Precision collet for the mounting of shanks with diameters d of 2 - 25 mm

Additional Information:

- Can be used with collet chuck C910 HSK-F 63

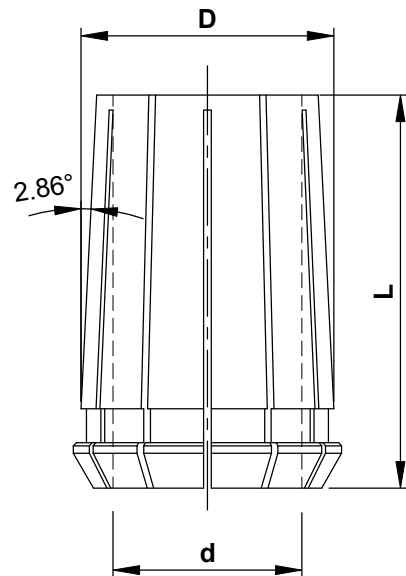

d	L	D	SPT	Ident-No.
2	52	33.4	1.5-2	C945-OZ25020
3	52	33.4	2.5-3	C945-OZ25030
4	52	33.4	3.5-4	C945-OZ25040
5	52	33.4	4.5-5	C945-OZ25050
6	52	33.4	5.5-6	C945-OZ25060
6.5	52	33.4	6-6.5	C945-OZ25065
8	52	33.4	7.5-8	C945-OZ25080
9.5	52	33.4	9-9.5	C945-OZ25095
10	52	33.4	9.5-10	C945-OZ25100
12	52	33.4	11.5-12	C945-OZ25120
13	52	33.4	12.5-13	C945-OZ25130
14	52	33.4	13.5-14	C945-OZ25140
16	52	33.4	15.5-16	C945-OZ25160
18	52	33.4	17.5-18	C945-OZ25180
20	52	33.4	19.5-20	C945-OZ25200
25	52	33.4	24.5-25	C945-OZ25250
1/4"	52	33.4	6.4	C945-OZ25014
3/8"	52	33.4	9.5	C945-OZ25038
1/2"	52	33.4	12.7	C945-OZ25012
3/4"	52	33.4	19.1	C945-OZ25034

Aigner
WERKZEUGE

e-mail: office@aigner-werkzeuge.at
www.aigner-werkzeuge.at

SPT.....Clamping Tolerance

Blattformat: **A4** All dimensions in mm

Zchnng.-Nr. KW.49450.4 | 01

C945-OZ25