

**Design:**

- Hollow taper shank in accordance with DIN 69893 Form F
- Manufactured in hardened and tempered tool steel
- Surface bright polished
- For the clamping of shanks in TC and steel
- For shaft tolerances h6 in accordance with EN 847-2
- System Ortlieb, taper ratio 1:10

**Application:**

- Clamping of tools with shanks by means of exchangeable collets (C945-OZ25xxx)
- Type OZ25 (system Ortlieb) in accordance with ISO 10897-B25
- Clamping tolerance 0.5 mm
- Clamping range 2-25 mm
- Observe the minimum clamping length for the respective cutter shank (marking on the shank in accordance with EN 847-2/6)
- Collet in accordance with ISO 10897 (formerly DIN 6388)

**Machine:**

- CNC machining centres

**Scope of supply:**

- Collet chuck
- Clamping nut

**Additional Information:**

- With clamped tools using collet chucks, the setting dimension A is measured with a clamping tolerance of 0.15 mm
- With the use of collet chucks with a clamping tolerance of 0.5 mm (C945-OZ25xxx), the dimension A is increased by 3-4 mm
- Tightening torque for the clamping nut  $M_a = 150 \text{ Nm}$

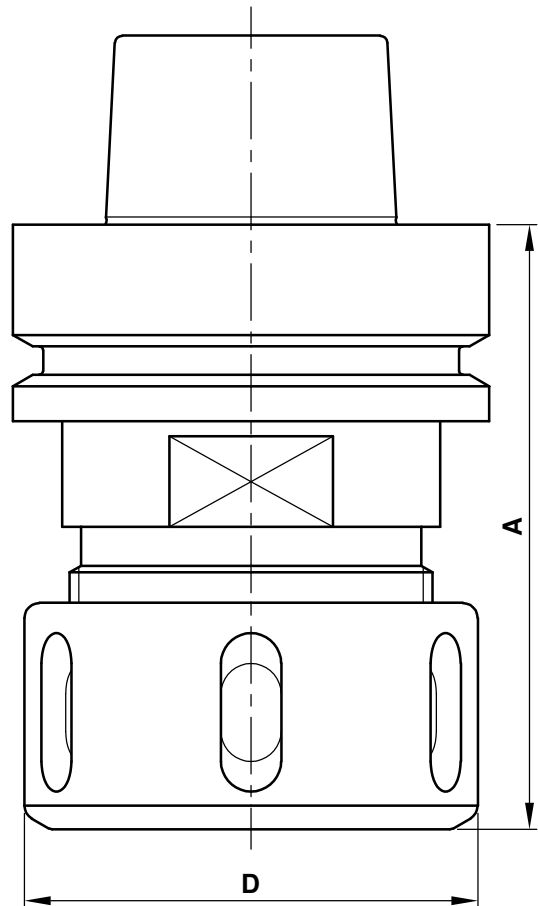

D	A	R/L	n max.	Ident-No.
60	76	R	24000	C910-76R
60	76	L	24000	C910-76L
60	115	R	24000	C910-115R

Spare Parts				
Description	Qty.	Dimensions	MBM	Ident-No.
C-wrench	1	58/62	1	C985
Clamping nut	1	M48x2 D60 mm	1	C910-482060

 <p>e-mail:office@aigner-werkzeuge.at www.aigner-werkzeuge.at</p>	n max.....Maximum Rotational Speed (rpm)	Blattformat: <b>A4</b>	All dimensions in mm Zchnng.-Nr. KW.49100.4   01
		C910	