

DP-Shank-Core-Box-Cutter

C869-1

Cutting Material

DP

Number of Teeth

Z 2

Feed

MEC

Bonded

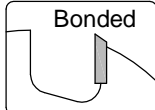

Design:

- Tool body in steel
- With two DP cutting edges
- Resharpenable 1 to 2 times
- Shank fit h6

Application:

- For the production of decorative grooves and profiling of mouldings

Workpiece Material:

- Panel materials

Machine:

- CNC machining centres

Scope of Supply:

- From shank 16 always with a length adjusting screw;
With use in shrink chuck HSK-F 63 (C915)
without a length adjusting screw
- Optionally also assembled (and balanced) (MS):
Assembled in shrink chuck HSK-F 63 (C915): C869-1....-M1
Assembled in collet chuck HSK-F 63 (C910): C869-1....-M2

Special Features:

- Suitable for moulding milling of compact panels

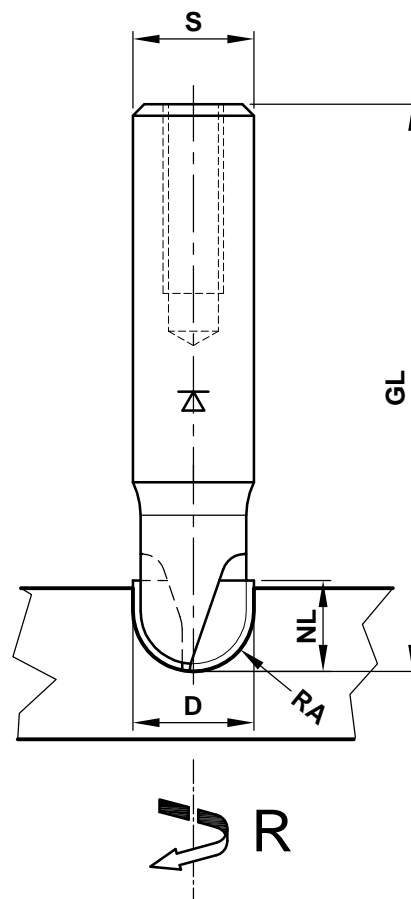

| D | RA | NL | GL | S | Z | R/L | n max. | Ident-No. |
|----|-----|------|----|----|---|-----|--------|-----------|
| 10 | 5 | 9 | 70 | 12 | 2 | R | 24000 | C869-150R |
| 13 | 6.5 | 10.5 | 70 | 12 | 2 | R | 24000 | C869-165R |
| 16 | 8 | 12 | 75 | 16 | 2 | R | 24000 | C869-180R |

Aigner
WERKZEUGE

e-mail: office@aigner-werkzeuge.at
www.aigner-werkzeuge.at

MS.....Machine Adaptor

Z.....No. of Teeth

n max.....Max. Speed (rpm)

Blattformat: **A4** All dimensions in mm

Zchnng.-Nr. KW.48691.4 | 00

C869-1