

DP-Shank-Grooving-Cutter-Roughing/Finishing

C863-3

Cutting Material
DP

Feed
MEC

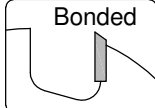

Number of Teeth
Z 3

Design:

- Tool body in Densimet
- No. of teeth = 3
- With DP plunging edge
- Can be resharpened up to 3 times
- Deep flutes for better chip collection
- Shank fit h6

Application:

- Grooving, jointing, rebating and sizing (cutting of) in nesting technique
- Roughing / Finishing

Workpiece material:

- Multiplex, HPL solid core panel machining
- formworkplywoods with phenolic resin-coating

Machine:

- CNC machining centres

Scope of supply:

- Principally with a length setting screw:
For use with shrink chucks HSK-F 63 (C915)
without a length setting screw
- Also optionally assembled (MS):
Assembled in shrink chuck HSK-F 63 (C915): C863-...-M1
Assembled in collet chuck HSK-F 63 (C910): C863-...-M2

Special features:

- Also very well suited to multiplex panels and HPL solid core panels
- suitable for high feed rates
- high chip removal

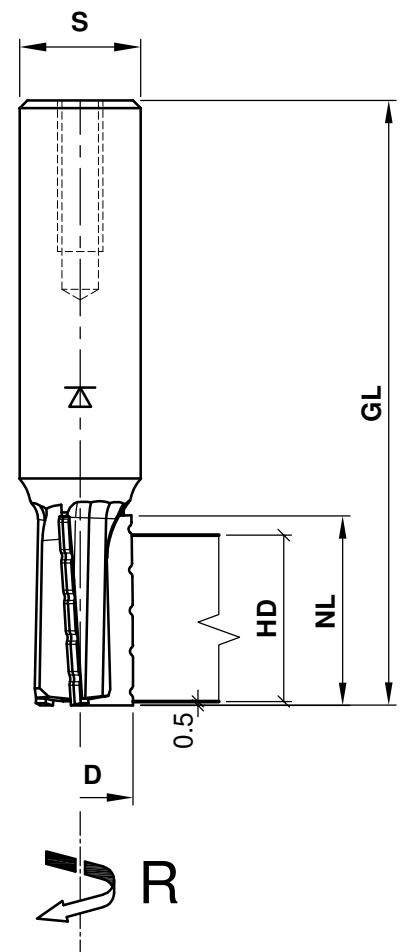

Running plunging

Circular plunging

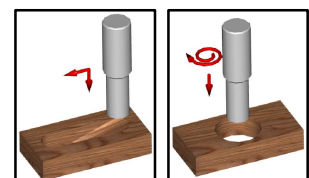

| D | NL | GL | HD | S | Z | R/L | n max. | Ident-No. |
|----|------|----|----|----|---|-----|--------|---------------|
| 14 | 25.0 | 80 | 22 | 16 | 3 | R | 24000 | C863-3142516R |

Aigner
WERKZEUGE

e-mail:office@aigner-werkzeuge.at
www.aigner-werkzeuge.at

MS.....Machine Adaptor

Z.....No. of teeth

n max.....Maximum Rotational Speed (rpm)

Blattformat: **A4** All dimensions in mm

Zchnng.-Nr. KW.48633.4 | 00

C863-3