

# DP-Shank-Grooving-Cutter-Roughing

C863-2

Cutting Material  
**DP**

Feed  
**MEC**

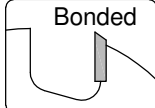

Number of Teeth  
**Z 3**

**Design:**

- Tool body in Densimet
- No. of teeth = 3
- With DP plunging edge
- Can be resharpened up to 3 times
- Deep flutes for better chip collection
- Shank fit h6

**Application:**

- Grooving, jointing, rebating and sizing (cutting of) in nesting technique
- Roughing

**Workpiece material:**

- Multiplex, HPL solid core panel machining
- formworkplywoods with phenolic resin-coating

**Machine:**

- CNC machining centres

**Scope of supply:**

- Principally with a length setting screw:  
For use with shrink chucks HSK-F 63 (C915)  
without a length setting screw
- Also optionally assembled (MS):  
Assembled in shrink chuck HSK-F 63 (C915): C863-...-M1  
Assembled in collet chuck HSK-F 63 (C910): C863-...-M2

**Special features:**

- Also very well suited to multiplex panels and HPL solid core panels
- suitable for high feed rates
- high chip removal

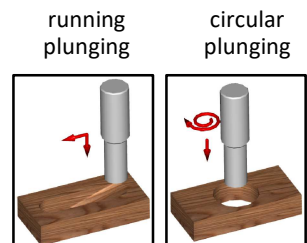
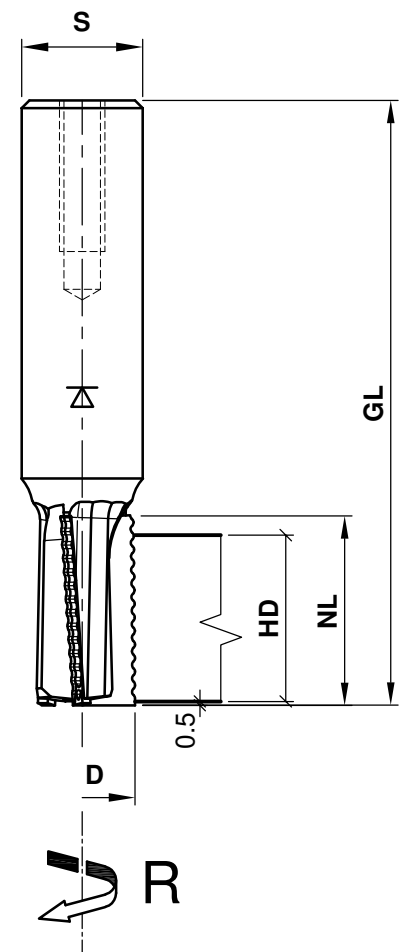

D	NL	GL	HD	S	Z	R/L	n max.	Ident-No.
14	25.0	80	22	16	3	R	24000	C863-2142516R

**Aigner**  
WERKZEUGE  
e-mail:office@aigner-werkzeuge.at  
www.aigner-werkzeuge.at

MS.....Machine Adaptor  
Z.....No. of teeth  
n max.....Maximum Rotational Speed (rpm)

Blattformat: **A4** All dimensions in mm  
Zchnng.-Nr. KW.48632.4 | 00

**C863-2**