

DP-Jointing-/ Rounding-Shank-Boring-Cutter

C860-3

Cutting Material
DP

Number of Teeth
Z2+BS

Feed
MEC

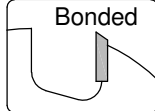

Design:

- Tool body in steel
- With two DP jointing / rounding cutting edges and one boring cutting edge
- Resharpenable 4 to 6 times
- Shank fit h6

Application:

- Boring, jointing, rounding and shaping with one tool
- Joints with land-free cuts; finish machining

Workpiece Material:

- Panel materials, especially HPL

Machine:

- CNC machining centres

Scope of Supply:

- Principally with a length adjustment screw;
With use in shrink chuck HSK-F 63 (C915)
without a length adjusting screw
- Optionally also assembled (and balanced) (MS):
Assembled in shrink chuck HSK-F 63 (C915): C860-3...-M1
Assembled in collet chuck HSK-F 63 (C910): C860-3...-M2

Special Features:

- Boring and joint milling possible without a tool change

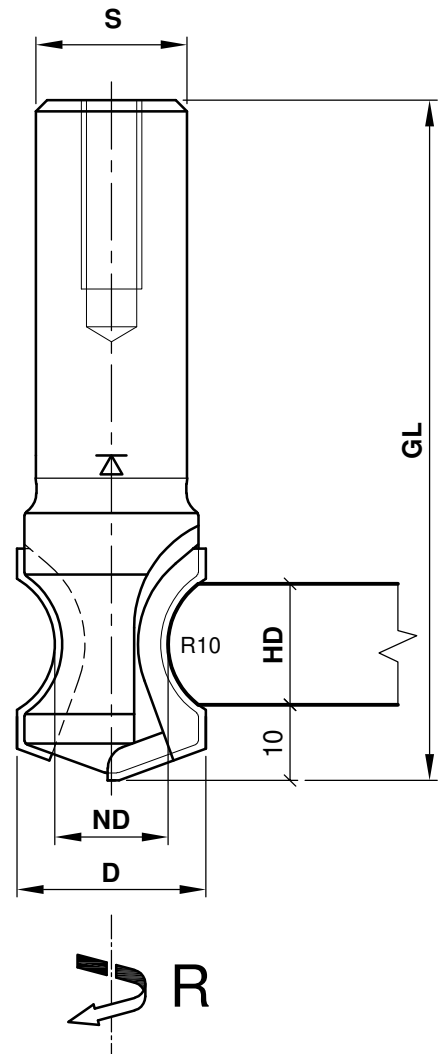

D	ND	GL	HD	Z	S	R/L	n max.	Ident-No.
25	15	90	16	2	20	R	24000	C860-31016R

Aigner
WERKZEUGE
e-mail: office@aigner-werkzeuge.at
www.aigner-werkzeuge.at

MS.....Machine Adaptor
Z.....No. of Teeth
n max.....Max. Speed (rpm)

Blattformat: **A4** All dimensions in mm
Zchnng.-Nr. KW.48603.4 01

C860-3