

Design:

- Multi-piece window set
- Tool body in steel
- No. of Teeth = 2
- TC profile knives
- TC reversible knives

Application:

- Production of casement windows

Workpiece Material:

- Solid wood

Machine:

- Spindle moulders

Scope of Supply:

- C690-FI12 (Casement-Inner)
- C690-250FS (Casement-Mortice-/ Inner)
- C690-250FZ12 (Casement-Tenon)

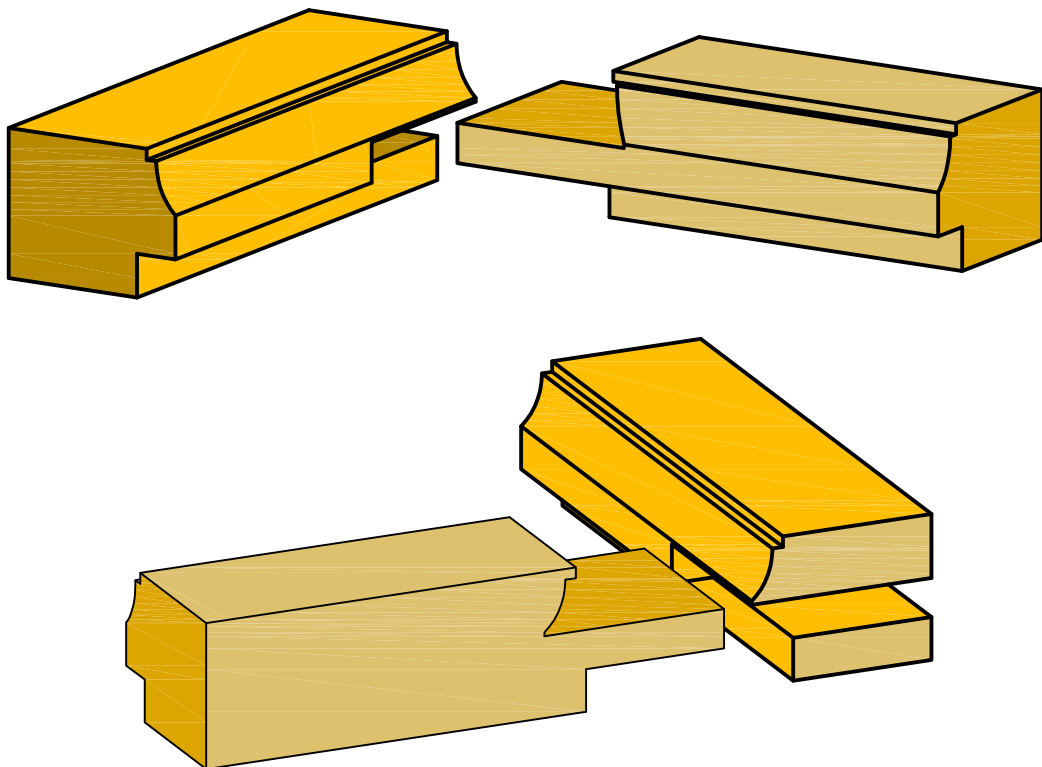

Design:

- Multi-piece window set
- Tool body in steel
- No. of Teeth = 2
- TC profile knives
- TC reversible knives

Application:

- Production of casement windows

Workpiece Material:

- Solid wood

Machine:

- Spindle moulders

Scope of Supply:

- C690-FI12 (Casement-Inner)
- C690-300FS (Casement-Mortice-/ Inner)
- C690-300FZ12 (Casement-Tenon)

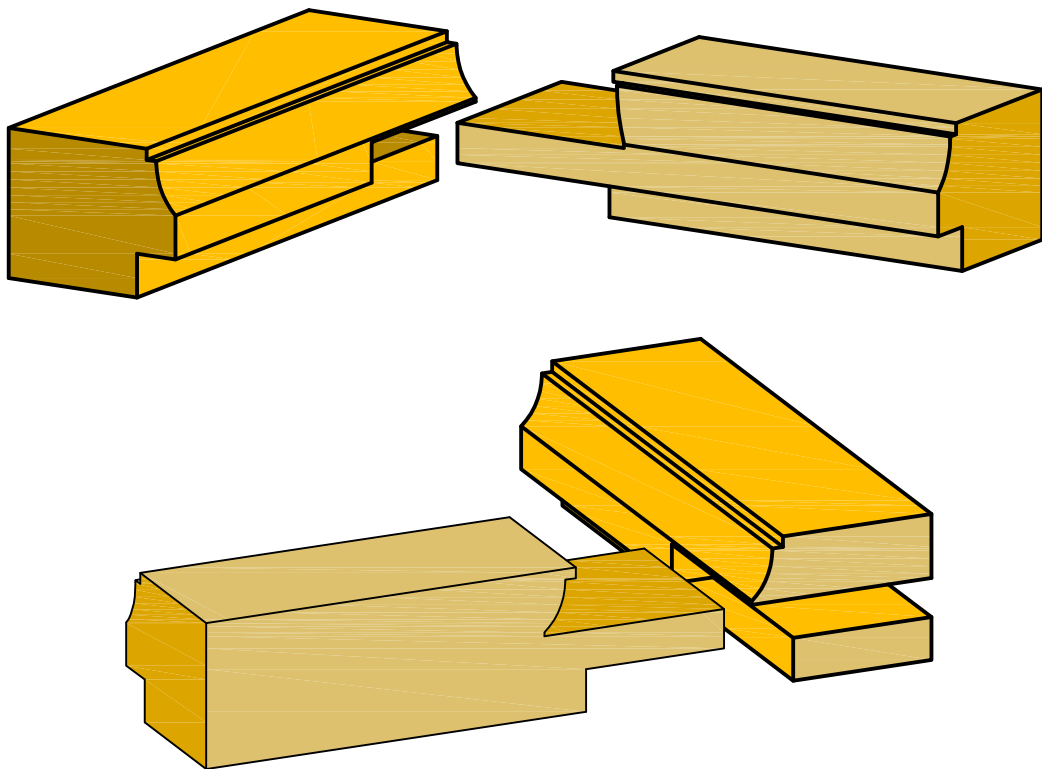

Cutting Material
TC

Number of Teeth
Z 2

Feed
MAN

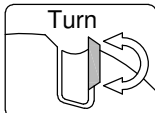
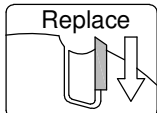

Design:

- Tool body in steel
- 2-piece set (screwed)
- No. of Teeth = 2
- PM profile knives
- WM reversible knives
- Bore up to maximum Ø40 possible for an additional charge

Application:

- For the production of casement windows EV41 in the listed building sector (profile "Old Vienna")

Workpiece Material:

- Solid wood

Machine:

- Spindle moulders

Scope of Supply:

- 2-piece cutter set incl. knives
- Cutter No.1 with PM.22580.5/U35 P1 pre-assembled
- If another knife is to be fitted it must be stated at the time of ordering
- The possible profile knives can be seen below

- 1 ring set 1.3mm
- 1 ring set 0.8mm
- 1 fixing ring 10mm
- 1 key with handle Torx T40
- 1 key with handle Torx T25
- 1 key with handle Torx T20
- 1 magnetic assembly jig

Special Features:

- Designed for use in combination with mortice set C690-1 and tenon set C690-2

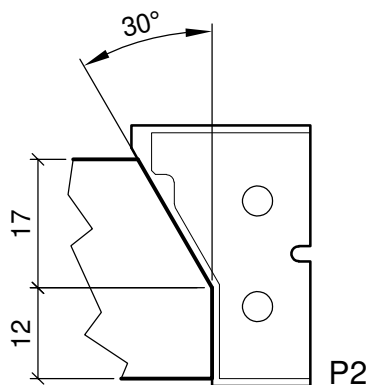
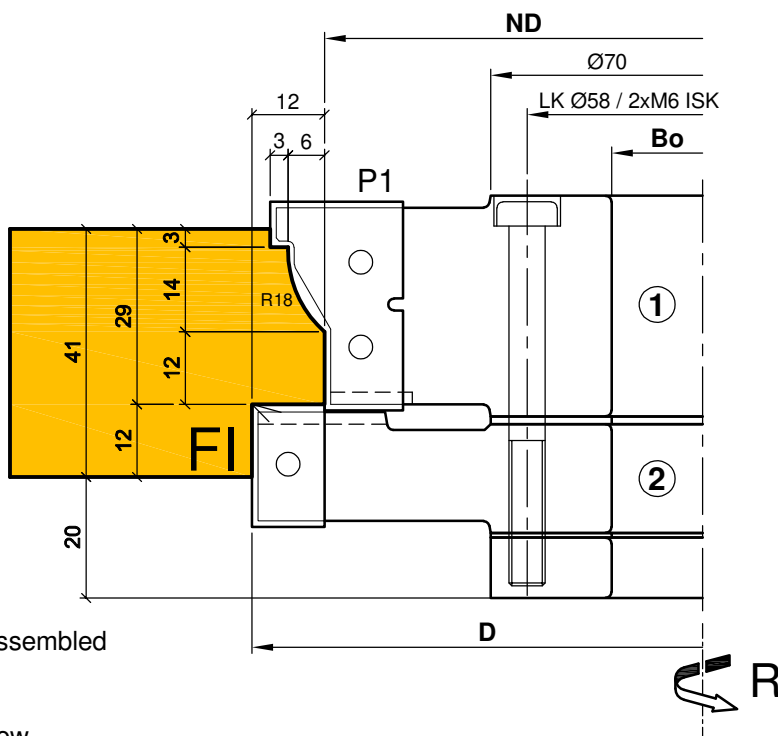

D	ND	Bo	Z	R/L	P	DZ	Ident-No.
149	125	30	2	R	1	5000-9000	C690-F112

Spare Parts				
Description	Qty.	Dimensions	MBM	Ident-No.
Profile knife P1 for No. 1	2	35x21.8x2	2	PM.22580.5/U35
Profile knife P2 for No.1 cham. (option)	2	35x21.8x2	2	PM.30264.5/U35
Indexable knife for No. 2	2	20x12x1.5	10	WMF20x12/U
Spur for No. 2	2	14x14x2.0	10	VS14x14x2.0/U
Screw spur for No. 2	2	Countersunk screw M6x10	10	KW.33767.4-10

<p>e-mail:office@aigner-werkzeuge.at www.aigner-werkzeuge.at</p>	Z.....No. of Teeth	Blattformat: A4 <small>All dimensions in mm</small>
	P.....Profile Variant	
DZ.....Speed Range (rpm)	C690-1	
MBM.....Minimum Order Quantity		

PM-Cutter-Set-EV41-Casement-Mortice-/ Tenon C690

Cutting Material
TC

Number of Teeth
Z 2

Feed
MAN

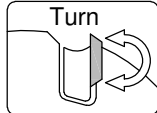
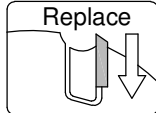

Design:

- Tool body in steel
- 1 or 2-piece set (screwed)
- No. of Teeth = 2
- PM profile knives
- Bore up to maximum Ø40 possible for an additional charge

Application:

- For mortice and tenon milling for casement window production EV41 in the listed building sector (profile "Old Vienna")

Workpiece Material:

- Solid wood

Machine:

- Spindle moulders

Scope of Supply:

- 2-piece cutter set incl. knives
- Cutter No.2 with PM.58351.5/M40 P1 pre-assembled
- If another knife is to be fitted it must be stated at the time of ordering
- The possible profile knives can be seen below
- Associated fixing rings and ring sets
- 1 key with handle Torx T40
- 1 key with handle Torx T15

Special Features:

- Designed for use in combination with set C690
- The same workpiece support and zero height for mortice and tenon milling

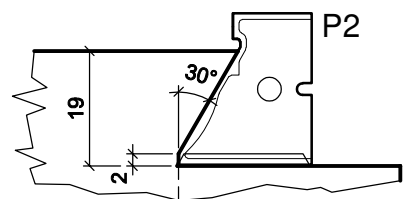
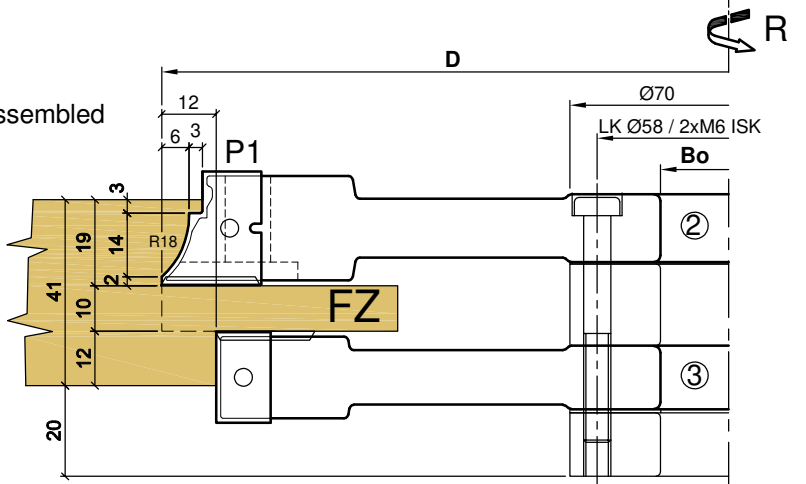
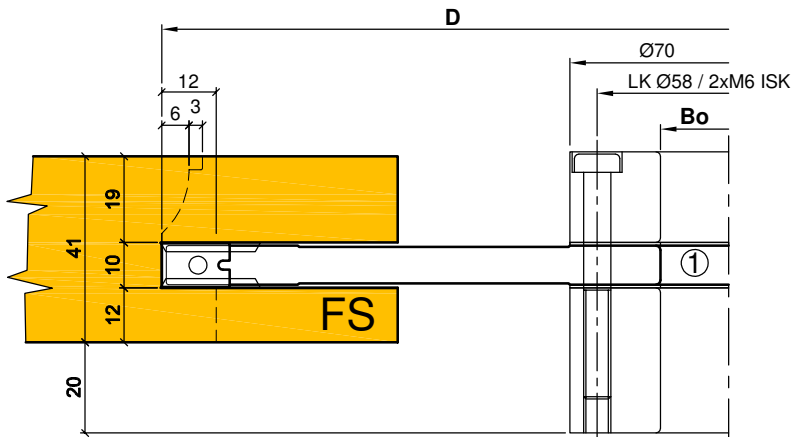

D	ND	Bo	Z	R/L	P	DZ	Ident-No.
250		30	2	R		3000-5500	C690-250FS
250		30	2	R	1	3000-5500	C690-250FZ12
300		30	2	R		2500-4500	C690-300FS
300		30	2	R	1	2500-4500	C690-300FZ12

Spare Parts		Qty.	Dimensions	MBM	Ident-No.
Profile knife for No. 1		2	9.6x15.0x2	2	PM.58350.5/M40
Profile knife P1 for No. 2		2	25.0x26.2x2	2	PM.58351.5/M40
Profile knife P2 for No.2 cham.(option)		2	25.0x26.2x2	2	PM.58352.5/M40
Reversible knife for No. 3		2	20x12x1.5	2	WMZ20x12/M
Spur for No. 1,2,3		4/2	22x22x2	10	VS3x22
Screw spur for No. 1		4	Countersunk screw M6x6	10	KW.33767.4-6
Screw spur for No. 2,3		2	Countersunk screw M6x10	10	KW.33767.4-10

Aigner
WERKZEUGE
e-mail:office@aigner-werkzeuge.at
www.aigner-werkzeuge.at

Z.....No. of Teeth
P.....Profile Variant
DZ.....Speed Range (rpm)
MBM.....Minimum Order Quantity

Blattformat: **A4** All dimensions in mm
Zchnng.-Nr. KW.46900.4 | 00
C690-2

Cutting Material TC	Number of Teeth Z 2	Feed MAN	Replace
-------------------------------	-------------------------------	--------------------	-------------

Design:

- Tool body in steel
- No. of Teeth = 2
- PM profile knives

Application:

- For re-milling deventer seal for casement windows EV41

Workpiece Material:

- Solid wood

Machine:

- Spindle moulders

Scope of Supply:

- Tool body incl. profile knives
- 1 key with handle Torx T15

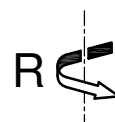
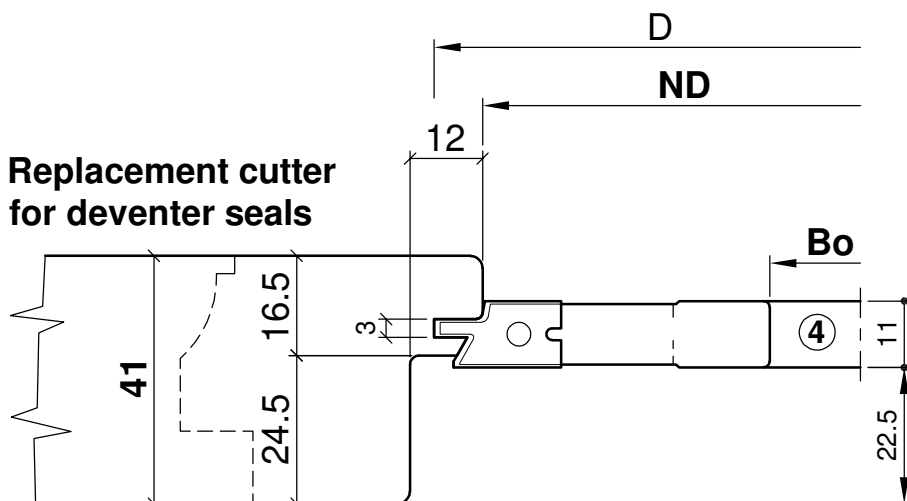

D	ND	Bo	Z	R/L	P	DZ	Ident-No.
141	125	30	2	R		4500-7500	C690-DEV

Spare Parts		Qty.	Dimensions	MBM	Ident-No.
Profile knife		2	11x21.7x2	2	PM.22593.5/M40

 e-mail:office@aigner-werkzeuge.at www.aigner-werkzeuge.at	Z.....No. of Teeth	Blattformat: A4	All dimensions in mm Zchnng.-Nr. KW.46900.4 00
	P.....Profile Variant		
	DZ.....Speed Range (rpm)	C690-3	
	MBM.....Minimum Order Quantity		