

# DP- Edge Rounding Cutter Konstantin®-Mini for KAM

# C560-1

Cutting Material <b>DP</b>	Number of Teeth <b>Z 4</b>	Feed <b>MEC</b>
-------------------------------	-------------------------------	--------------------

**Design:**

- Tool body in steel
- No. of teeth = 4
- Cutting elements fitted with DP (DIA)
- Rounding cutter with replaceable DP cutters
- Deep chip spaces for better chip capture

**Application:**

- Rounding of solid wood edges as well as veneer and plastic edges

**Workpiece Material:**

- Solid wood edges as well as veneer and plastic edges

**Machine:**

- Edgebanding machine HOLZ-HER Aggregat 1833

**Scope of Supply:**

- Tool body including DP cutter R2 pre-assembled  
If another cutter is to be fitted it must be stated when ordering  
The possible profile cutters can be seen below
- Handle key Torx T10

**Special Features:**

- Constant diameter when replacing knives
- Same zero diameter for all radii
- Various radius can be fitted

**Additional Information:**

- A torque wrench is recommended for the changing of the knives (see C986-FT1810)

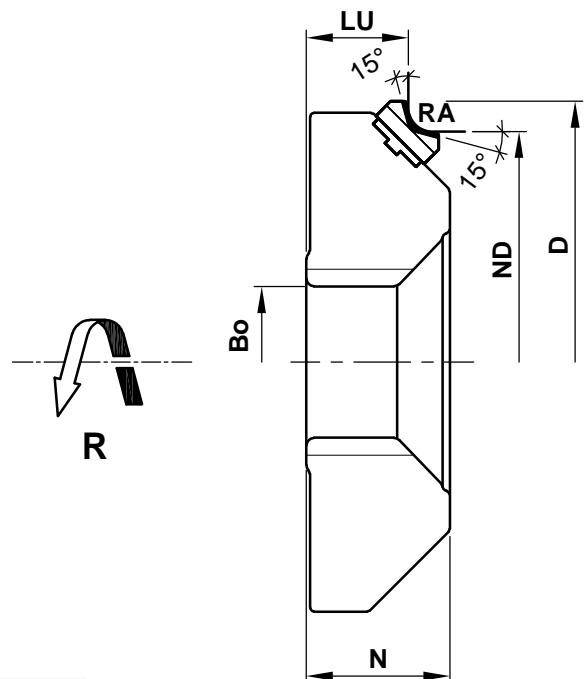

**Profile knives**

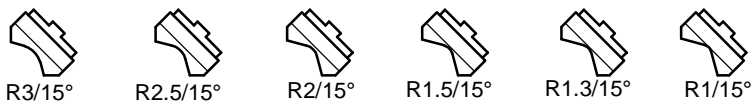

D	ND	Bo	LU	Z	RA	P	R/L	MA	Ident-No.
69	61	20	13.5	4	R2	R1-R3	R	Holz-Her(1833)	C560-1AR
69	61	20	13.5	4	R2	R1-R3	L	Holz-Her(1833)	C560-1AL

**Aigner**  
WERKZEUGE  
e-mail:office@aigner-werkzeuge.at  
www.aigner-werkzeuge.at

Z.....No. of teeth  
P.....Profile Variant  
n max.....Max. Speed (rpm)  
MBM.....Minimum Order Quantity

Blattformat: **A4** All dimensions in mm  
Zchnng.-Nr. KW.45601.4 | 00  
**C560-1**

<b>Spare Parts</b>				
<b>Description</b>	<b>Qty.</b>	<b>Dimensions</b>	<b>MBM</b>	<b>Ident-No.</b>
<b>C560-1AR1-R3R /C560-1AR1-R3L</b>				
Replaceable knife R1.0 (option)	2	9x9x2.5	2	KW.21679.7/B25
Replaceable knife R1.3 (option)	2	9x9x2.5	2	KW.21680.7/B25
Replaceable knife R1.5 (option)	2	9x9x2.5	2	KW.21681.7/B25
Replaceable knife R2.0	2	9x9x2.5	2	KW.21682.7/B25
Replaceable knife R2.5 (option)	2	9x9x2.5	2	KW.21683.7/B25
Replaceable knife R3.0 (option)	2	9x9x2.5	2	KW.21684.7/B25
<b>Spare Parts</b>				
<b>Description</b>	<b>Qty.</b>	<b>Dimensions</b>	<b>MBM</b>	<b>Ident-No.</b>
Clamping screw replaceable knife	4	Countersunk screw M3x6 T10	10	KW.15714.7

 e-mail:office@aigner-werkzeuge.at www.aigner-werkzeuge.at	Blattformat: <b>A4</b> <small>All dimensions in mm</small>	
	Zchnng.-Nr. KW.45601.4	00
		<b>C560-1-1</b>