

Cutting Material
TC

Number of Teeth
Z 2

Feed
MAN

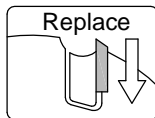

Design:

- 4-piece cutter set, pinned
- Tool body in steel
- Number of teeth = 2
- TC profile cutters
- Drawing cut
- Bore up to max. $\varnothing 40$ at extra cost

Application:

- For the milling of all rebates necessary for the production of house doors on stationary machines
- For solid wood and various composite materials (house door corner angles)
- Can also be optionally used for inner door rebates

Workpiece material:

- Solid wood and panel materials

Machine:

- Spindle moulders

Scope of supply:

- Tool body including profile cutters
With milling cutter No. 1 PM.20164.5/U35 R2.5 pre-assembled and all sealing groove cutters SB4
If another cutter is to be used this must be stated when ordering
The possible cutters can be seen on the following page
- Key with handle Torx T40
- Allen key with handle SW5
- Key with handle Torx T25
- Ring set 25mm

Special features:

- All house door rebate variants with just one set of cutters
- Casement outer rebating uprights and top
Bottom (optional cutter No. 5)
Middle closure (secondary sash)
- Frame inner upright and top counter

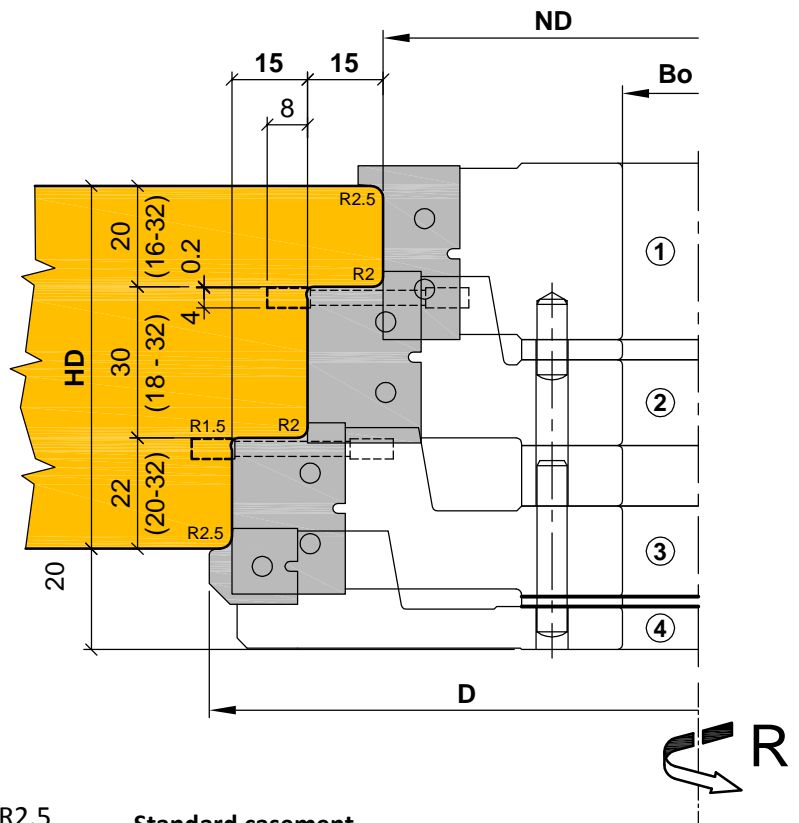

Standard casement rollover profile

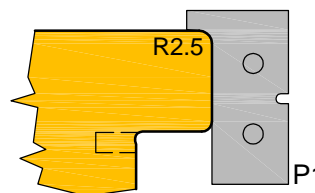

Optional casement rollover profile

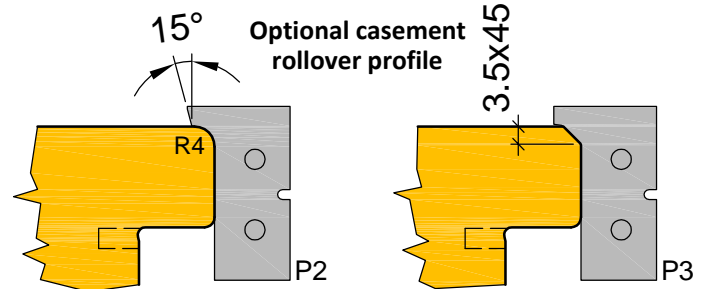

Optionally Available

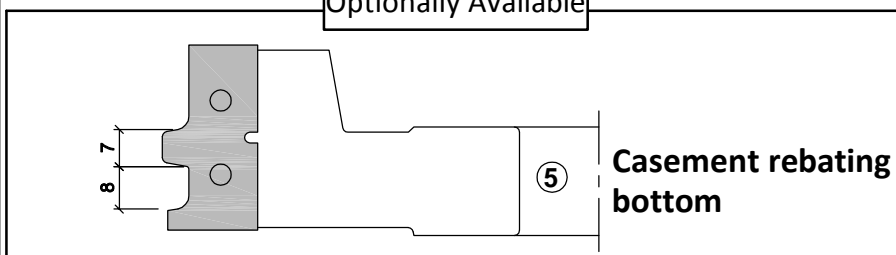

Casement rebating bottom

Aigner
WERKZEUGE

e-mail: office@aigner-werkzeuge.at
www.aigner-werkzeuge.at

Blattformat: **A4** All dimensions in mm

Zchnng.-Nr. KW.45430.4 | 00

C543

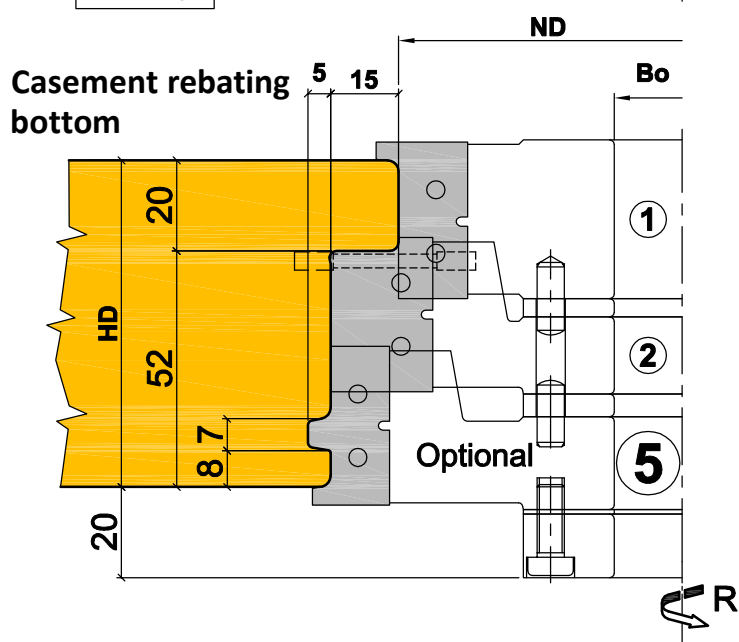
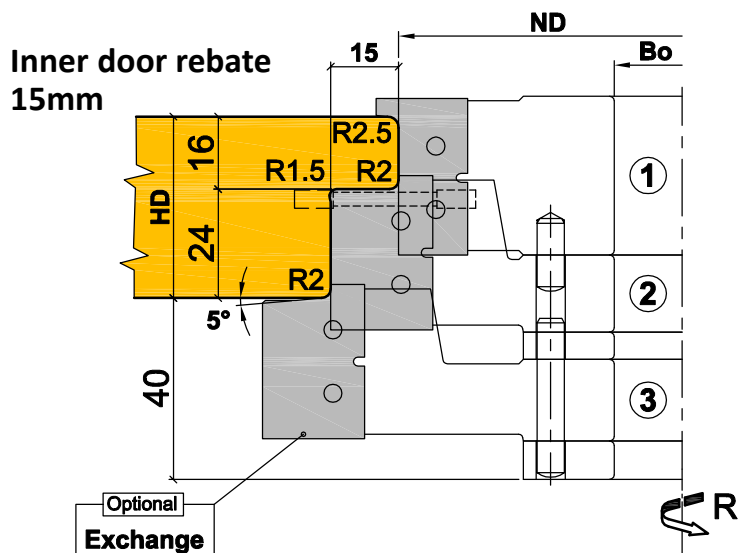

D	ND	HD	Bo	Z	V	FA	P	R/L	DZ	Ident-No.
194	125	68-80	30	2		1+2+3+4	R2.5	R	4000-7000	C543
194	125	68-80	30	2		5		R	4000-7000	C543-5

Spare Parts		Qty.	Dimensions	MBM	Ident-No.
Profile Cutter P1 for No. 1 R2.5		2	35x18.5x2.0	2	PM.20164.5./U35
Profile Cutter P2 for No. 1 R4 (option)		2	35x18.5x2.0	2	PM.20182.5./U35
Profile Cutter P3 for No. 1 Chamfer (o.)		2	35x18.5x2.0	2	PM.20183.5./U35
Profile Cutter for No. 2		2	35x23.5x2.0	2	PM.20092.5./U35
Profile Cutter for No. 3		2	35x23.5x2.0	2	PM.20092.5./U35
Profile Cutter for No. 3 (option)		2	35x23.5x2.0	2	PM.20184.5./U35
Profile Cutter for No. 4		2	15x17.8x2.0	2	PM.20095.5./U35
Profile Cutter for No. 5		2	35x18.6x2.0	2	PM.20231.5./U35
Grooving Cutter SB4		2	40x25x4.0	2	KW.08061.5
Grooving Cutter SB5 (option)		2	40x25x5.0	2	KW.08057.5
Screw Grooving Cutter		2	Grooving Cutter Screw M6x16	2	KW.04111.5

 <p>e-mail: office@aigner-werkzeuge.at www.aigner-werkzeuge.at</p>	Z.....No. of teeth FA.....No. of Cutters	Blattformat: A4 <small>All dimensions in mm</small>
	P.....Profile Variants	Zchnng.-Nr. KW.45430.4 00
DZ.....Speed Range (rpm)	C543-1	
MBM.....Minimum Order Quantity		

Casement rebating upright and top

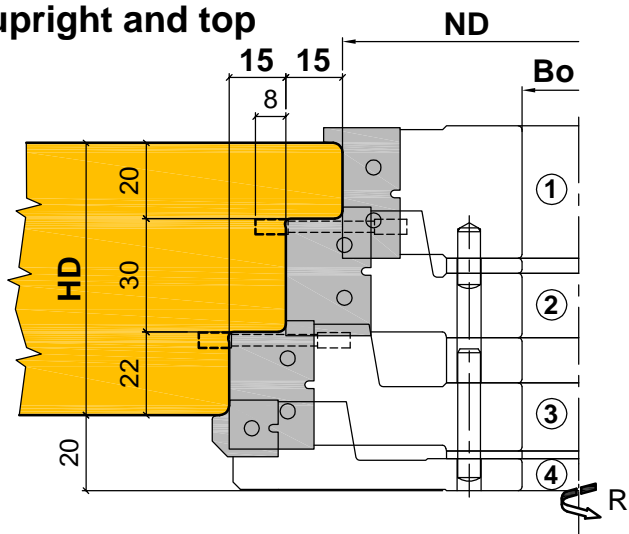

Frame counter inner upright and top

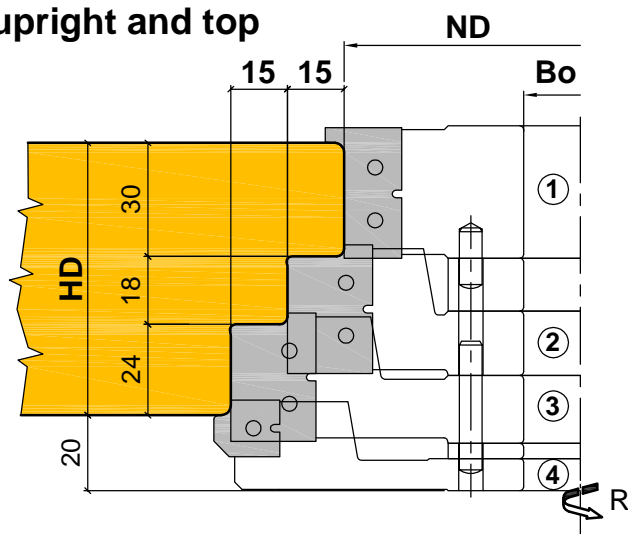

Standard Setting:
HD: 72mm

Middle closure (left casement)

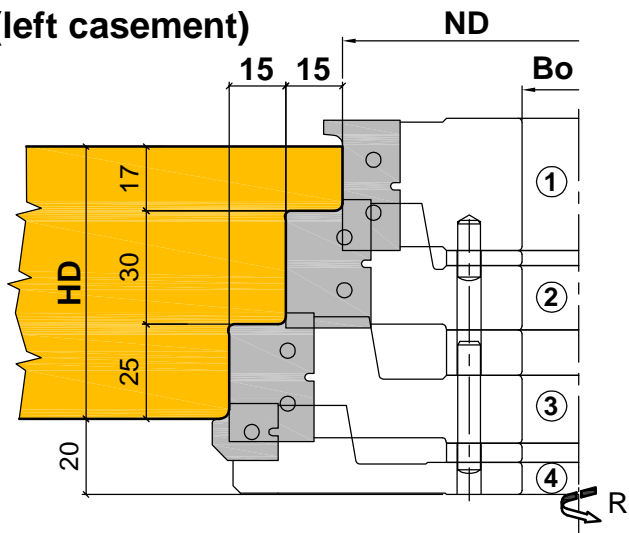

Frame inner upright and top

