

DP-Rounding/Bevel/Joining Cutter Set Konstantin® C491-3

Cutting Material

DP

Feed

MEC

Number of Teeth

Z 2

Design:

- 3-part cutter set
- No. of teeth = 2
- Joining cutter head and bevel / rounding cutters with replaceable DP knives
- Tool body in light alloy
- Cutting elements fitted with DP (DIA)
- Pulling cut in the joining area
- Low-noise design
- 2-3 times resharpenable
- With TC safety cutter

Application:

- For the rounding / bevelling of panel materials on CNC milling machines

Workpiece Material:

- Panel materials

Machine:

- CNC machining centres

Scope of Supply:

- Tool body including DP cutters
- Bevel / rounding cutter R2 with Nr.1 and Nr.4 / R5 with Nr.2 and Nr.5 / R6 with Nr.3 and Nr.6 pre-assembled
- If another knife is to be fitted, it must be stated at the time of order
- Handle key Torx T25
- Handle key Torx T20
- Optionally also assembled (and balanced) (MS):
Assembled on milling arbor
HSK-F 63 (C905-4530080): C491-3...-F1
Assembled on milling arbor
HSK-F 63 (C905-8030080): C491-3...-F2

Special Features:

- Same zero diameter (run-off edge) for all radii
- Different radii available
- Safety cutter for the protection of the tool body Against damage

Additional Information:

- For individual cutters, see C491-1

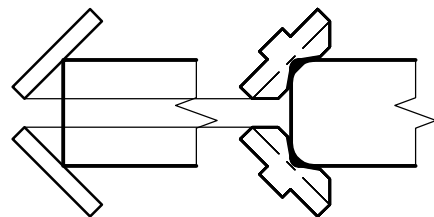
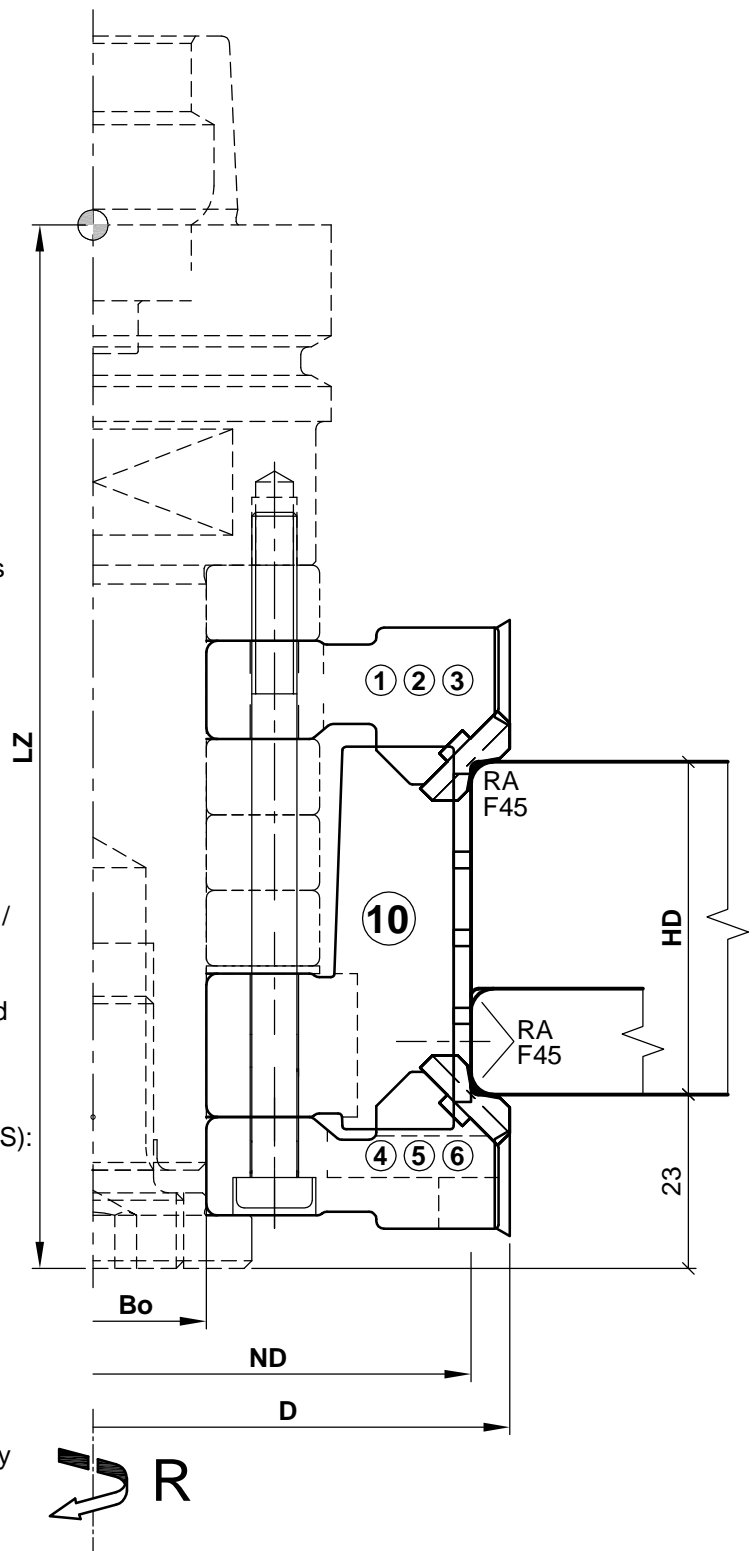

Aigner
WERKZEUGE

e-mail: office@aigner-werkzeuge.at
www.aigner-werkzeuge.at

MS.....Machine Interface

Blattformat: A4 All dimensions in mm

Zchnng.-Nr. KW.44913.4 00

C491-3

DP-Rounding/Bevel/Joining Cutter Set Konstantin® C491-3

D	ND	HD	Bo	LZ	Z	R/L	FA	RA	P	n max.	Ident-No.
110.3	100	14-44	30		2	R	1+10+4	R1-R3/F45	R2	14100	C491-31343R
110.3	100	14-44	30	138	2	R	1+10+4	R1-R3/F45	R2	14100	C491-31343R-F1
110.3	100	14-44	30	173	2	R	1+10+4	R1-R3/F45	R2	14100	C491-31343R-F2
112.2	100	14-45	30		2	R	2+10+5	R4-R5/F45	R5	14100	C491-34543R
112.2	100	14-45	30	138	2	R	2+10+5	R4-R5/F45	R5	14100	C491-34543R-F1
112.2	100	14-45	30	173	2	R	2+10+5	R4-R5/F45	R5	14100	C491-34543R-F2
113.2	100	14-47	30		2	R	3+10+6	R6/F45	R6	14100	C491-3643R
113.2	100	14-47	30	138	2	R	3+10+6	R6/F45	R6	14100	C491-3643R-F1
113.2	100	14-47	30	173	2	R	3+10+6	R6/F45	R6	14100	C491-3643R-F2

Spare Parts				
Description	Qty.	Dimensions	MBM	Ident-No.
Replaceable knife for jointing cutter	8	14.5x14.1x4.7	2	KW.97479.4/B02
Replaceable knife for rounding cutter R1 (option)	4	14.5x14.9x6.8	2	KW.21572.7/B02
Replaceable knife for rounding cutter R1.5 (option)	4	14.5x14.9x6.8	2	KW.21573.7/B02
Replaceable knife for rounding cutter R2	4	14.5x14.9x6.8	2	KW.21574.7/B02
Replaceable knife for rounding cutter R2.5 (option)	4	14.5x14.9x6.8	2	KW.21575.7/B02
Replaceable knife for rounding cutter R3 (option)	4	14.5x14.9x6.8	2	KW.21576.7/B02
Replaceable knife for rounding cutter R4 (option)	4	14.5x14.9x6.8	2	KW.22103.7/B02
Replaceable knife for rounding cutter R5	4	14.5x14.9x6.8	2	KW.22104.7/B02
Replaceable knife for rounding cutter R6	4	14.5x14.9x6.8	2	KW.22105.7/B02
Replaceable knife for bevel cutter (option)	4	14.5x14.1x4.7	2	KW.97479.4/B02
Clamping screw main cutter	12	Tapered screw T25 M6x14	10	KW.93706.4-14
Spur	4	14x14x2.0	10	VS14x14x2.0/U
Screw for spur	4	Countersunk screw M6x10	10	KW.33767.4-10

 <p>e-mail:office@aigner-werkzeuge.at www.aigner-werkzeuge.at</p>	LZ.....Total length (Z dim.)	Blattformat: A4 <small>All dimensions in mm</small>
	P.....Profile variant FA.....No. of cutters	Zchnng.-Nr. KW.44913.4 00
n max.....Max speed (rpm)	C491-3-1	
MBM.....Minimum Order Quantity		