

DP-Jointing / -Rebating-End-Mill "Speedy"

C450

Cutting Material DP	Feed MEC	Bonded 	Number of Teeth Z2+2
-------------------------------	--------------------	---------------------------------------------------------------------------------------------	--------------------------------

Design:

- Robust tool body with helically arranged cutters
- Z2 with DP cross cutter
- Can be re-sharpened 4 to 6 times
- Deep flutes for better chip collection
- Shank fit h6

Application:

- Jointing and rebating

Workpiece material:

- Solid wood and panel materials

Machine:

- CNC machining centres

Scope of supply:

- Principally with a length setting screw:
For use with shrink chucks HSK-F 63 (C915)
without a length setting screw
- Also optionally assembled (MS):
Assembled in shrink chuck HSK-F 63 (C915): C450-...-M1
Assembled in collet chuck HSK-F 63 (C910): C450-...-M2

Special features:

- Speedy end mill very well suited to sizing and fine jointing of laminated wood and solid wood

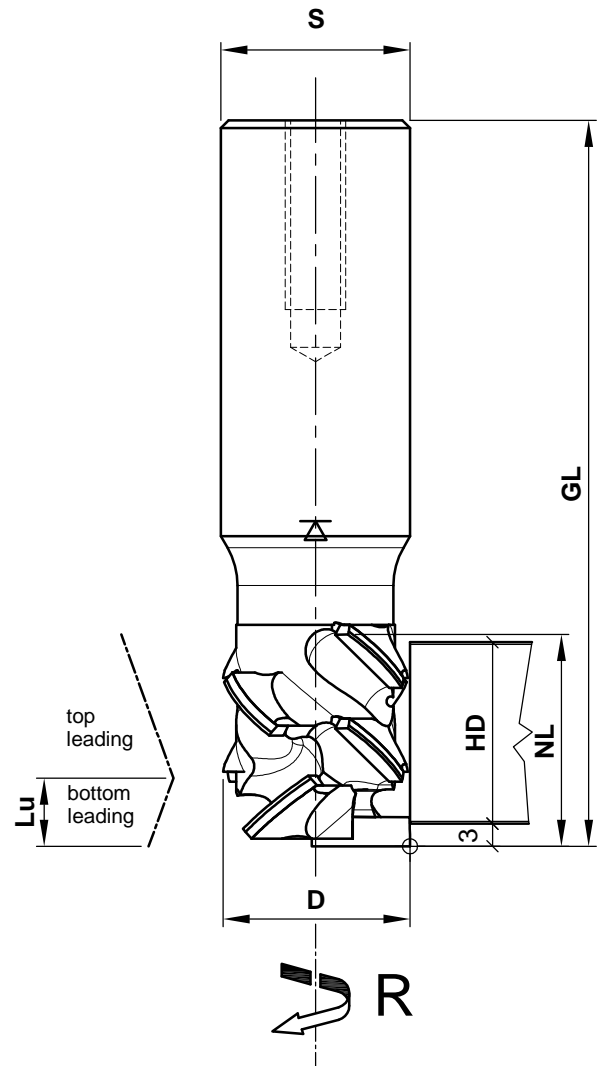

D	NL	GL	Lu	HD	S	Z	R/L	n max.	Ident-No.
20	29.6	96	9	25	25	2	R	24000	C450-20296R
20	29.6	96	9	25	25	2	L	24000	C450-20296L
20	46	116	15	42	25	2	R	24000	C450-2046R
20	46	116	15	42	25	2	L	24000	C450-2046L
25	28	96	9	24	25	2	R	24000	C450-2528R
25	28	96	9	24	25	2	L	24000	C450-2528L
25	46	116	16	42	25	2	R	24000	C450-2546R
25	46	116	16	42	25	2	L	24000	C450-2546L

 <p>e-mail:office@aigner-werkzeuge.at www.aigner-werkzeuge.at</p>	MS.....Machine Adaptor	Blattformat: A4	<small>All dimensions in mm</small> Zchnng.-Nr. KW.44500.4 01
	Z.....No. of teeth	C450	
n max.....Maximum Rotational Speed (rpm)			