

# DP-End-Mill "Nesting"

C440

Cutting Material  
**DP**

Feed  
**MEC**

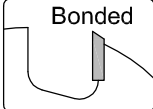

**Design:**

- No. of teeth = 3+3 (Tool body in Densimet)
- With DP plunging edge
- Can be re-sharpened up to 2 times
- Deep flutes for better chip collection
- Shank fit h6

**Application:**

- Grooving jointing, rebating and sizing (cutting off) in nesting technique

**Workpiece material:**

- Panel materials

**Machine:**

- CNC machining centres

**Scope of supply:**

- Principally with a length setting screw:  
For use with shrink chucks HSK-F 63 (C915)  
without a length setting screw
- Also optionally assembled (MS):  
Assembled in shrink chuck HSK-F 63 (C915): C440-...-M1  
Assembled in collet chuck HSK-F 63 (C910): C440-...-M2

**Special features:**

- Also very well suited to multiplex panels
- For high feed rates

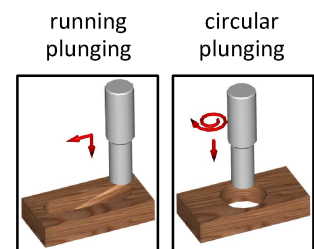
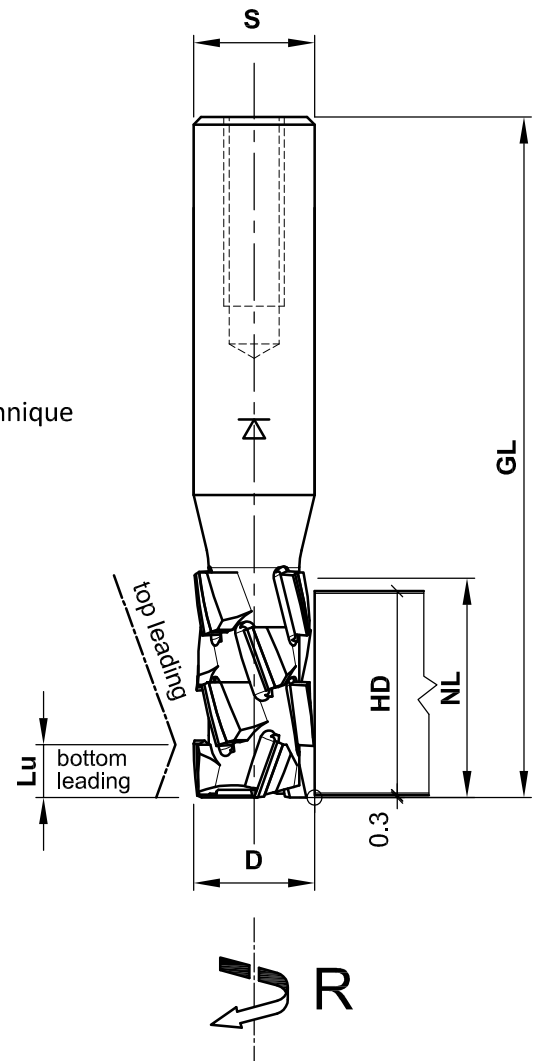

D	NL	GL	Lu	HD	S	Z	M	R/L	n max.	Ident-No.
14	27.1	75	5	22	16	3+3	DE	R	24000	C440-1427R
16	29.4	84	7	24	16	3+3	DE	R	24000	C440-1629R

 <p>e-mail: office@aigner-werkzeuge.at www.aigner-werkzeuge.at</p>	MS.....Machine Adaptor	Blattformat: <b>A4</b>	<small>All dimensions in mm</small> Zchnng.-Nr. KW.44400.4   00
	Z.....No. of teeth	C440	
n max.....Maximum Rotational Speed (rpm)			