

DP-Grooving-End-Mill "ECO"

C435

Number of Teeth
Z1+1

Cutting Material
DP

Feed
MEC

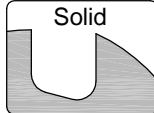

Design:

- Tool body in Q & T steel; with TC plunge cutters
- Z1+1 in two flutes (spiral)
- Can be re-sharpened 2 to 4 times
- Deep flutes for better chip collection
- Shank fit h6

Application:

- Grooving jointing, rebating and sizing (cutting off)

Workpiece material:

- Panel materials

Machine:

- CNC machining centres

Scope of supply:

- Principally with a length setting screw:
For use with shrink chucks HSK-F 63 (C915)
without a length setting screw
- Also optionally assembled (MS):
Assembled in shrink chuck HSK-F 63 (C915): C435-...-M1
Assembled in collet chuck HSK-F 63 (C910): C435-...-M2

Special features:

- Dia router suitable for basic equipment and low feeds

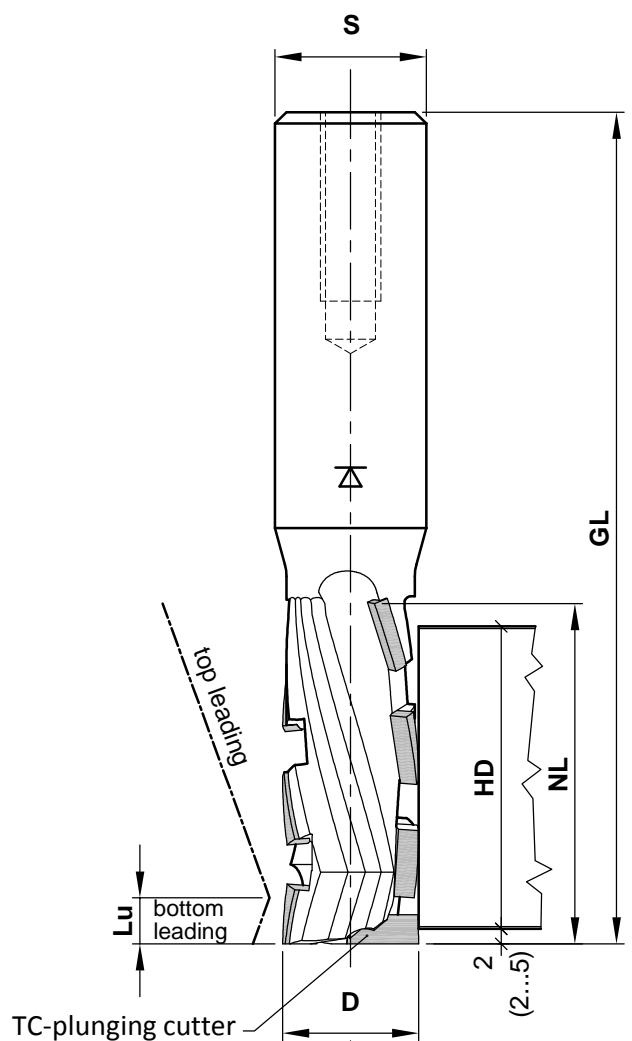

D	NL	GL	Lu	HD	S	Z	R/L	n max.	Ident-No.
10	23	80	5	19	16	1+1	R	24000	C435-1023R
10	23	80	5	19	16	1+1	L	24000	C435-1023L
12	26	85	8	22	16	1+1	R	24000	C435-1226R
16	31	95	7	25	20	1+1	R	24000	C435-1629R
16	31	95	7	25	20	1+1	L	24000	C435-1629L
16	38	100	7	35	20	1+1	R	24000	C435-1638R
16	45	110	7	40	20	1+1	R	24000	C435-1645R
16	45	110	7	40	20	1+1	L	24000	C435-1645L
18	31	95	7	25	20	1+1	R	24000	C435-1829R
18	38	100	7	35	20	1+1	R	24000	C435-1838R
18	38	100	7	35	20	1+1	L	24000	C435-1838L
18	45	110	7	40	20	1+1	R	24000	C435-1845R
18	45	110	7	40	20	1+1	L	24000	C435-1845L
20	31	95	7	25	20	1+1	R	24000	C435-2029R
20	31	95	7	25	20	1+1	L	24000	C435-2029L
20	38	100	7	35	20	1+1	R	24000	C435-2038R
20	45	110	7	40	20	1+1	R	24000	C435-2045R
20	45	110	7	40	20	1+1	L	24000	C435-2045L
20	53	115	7	48	20	1+1	R	24000	C435-2053R
20	53	115	7	48	20	1+1	L	24000	C435-2053L

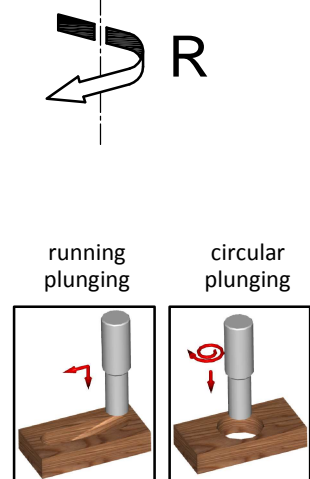

Aigner
WERKZEUGE
e-mail:office@aigner-werkzeuge.at
www.aigner-werkzeuge.at

MS.....Machine Adaptor
Z.....No. of teeth
n max.....Maximum Rotational Speed (rpm)

Blattformat: **A4** All dimensions in mm
Zchnng.-Nr. KW.44350.4 | 01

C435