

DP-Jointing-Cutter Konstantin®

C420-3

Cutting Material
DP

Feed
MEC

Number of
Teeth
Z 2

Design:

- Jointing cutter head with replaceable DP cutters
- Tool body in light alloy
- Cutting elements tipped with DP (DIA)
- Drawing cut
- Low-noise design
- Can be re-sharpened 2 to 3 times

Application:

- For low-noise jointing of panel materials

Workpiece material:

- Panel materials

Machine:

- CNC machining centres

Scope of supply:

- Tool body including DP cutters
- Torx key T25
- Also optionally assembled (and balanced) (MS):
Mounted on milling arbor HSK-F 63 (C905-4530xx): C420-...-F1
Mounted on milling arbor HSK-F 63 (C905-8030xx): C420-...-F2

Special features:

- Pure jointing cutter without spurs

Additional Information:

- A torque wrench (see C986-D315) is recommended when changing the cutters

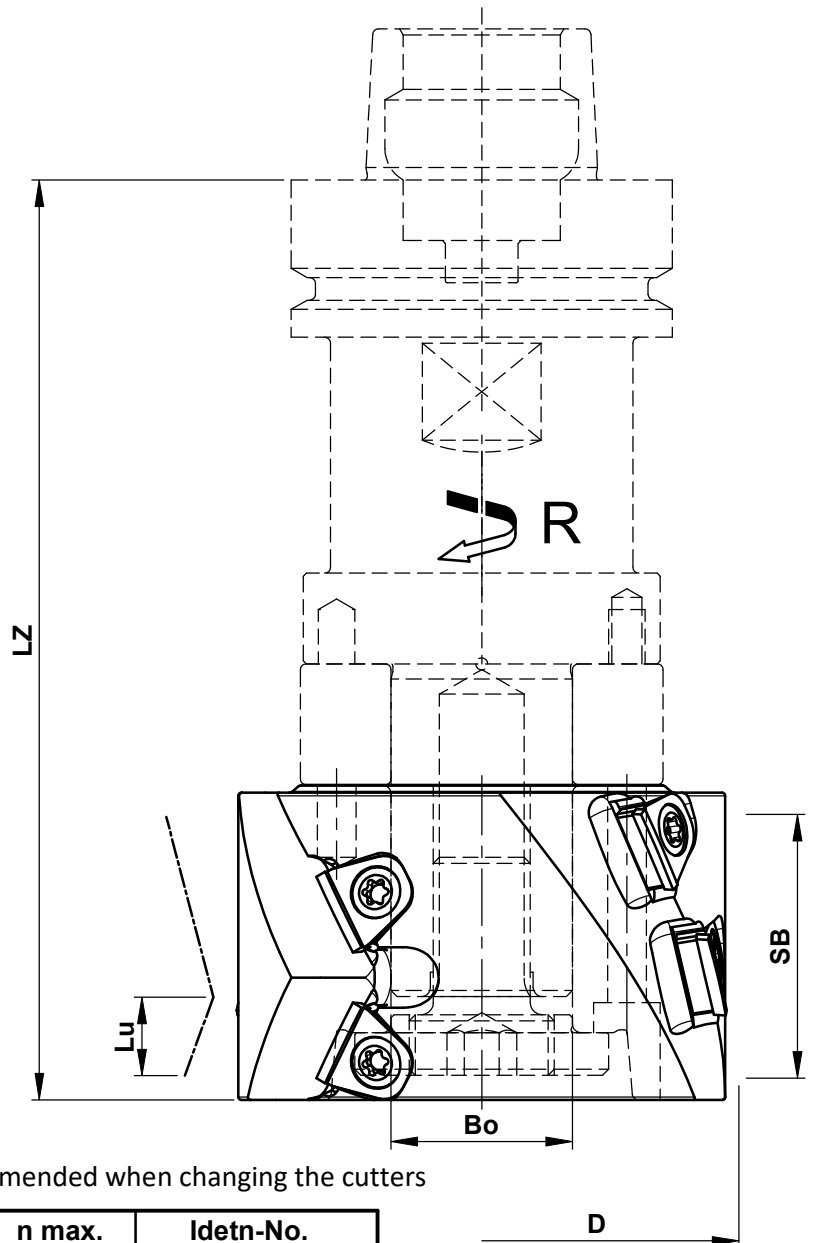

D	SB	Lu	Bo	LZ	Z	R/L	n max.	Idetn-No.
85	44	12	30		2	R	15500	C420-38544R
85	44	12	30	117.1	2	R	15500	C420-38544R-F1
85	44	12	30	152.1	2	R	15500	C420-38544R-F2
85	54	12	30		2	R	15500	C420-38554R
85	54	12	30	117.1	2	R	15500	C420-38554R-F1
85	54	12	30	152.1	2	R	15500	C420-38554R-F2
85	64	12	30		2	R	15500	C420-38564R
85	64	12	30	117.6	2	R	15500	C420-38564R-F1
85	64	12	30	152.6	2	R	15500	C420-38564R-F2

Spare Parts				
Description	Qty.	Dimensions	MBM	Ident-No.
DP Main Cutter SB 44	8	14.5x14.1x4.7	2	KW.97927.4/B02
DP Main Cutter SB 54	10	14.5x14.1x4.7	2	KW.97927.4/B02
DP Main Cutter SB 64	12	14.5x14.1x4.7	2	KW.97927.4/B02
Clamping Screw		M6x14	10	KW.93706.4-14

 <p>e-mail:office@aigner-werkzeuge.at www.aigner-werkzeuge.at</p>	MS.....Machine Adaptor	Blattformat: A4 <small>All dimensions in mm</small>
	Z.....No. of teeth	Zchnng.-Nr. KW.44203.4 00
n max.....Maximum Rotational Speed (rpm)	C420-3	
MBM.....Minimum Order Quantity		