

Cutting Material
TC

Feed
MAN

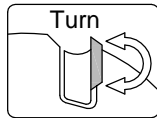

Design:

- Tool body in steel
- At D100, bore up to max $\varnothing 40$ possible at extra cost
- At D125 and D140, bore up to max $\varnothing 50$ possible at extra cost
- Z2/V4 with axially parallel cut
- Z4 WZ/V4 with alternating drawing cuts
- TC reversible cutter

Application:

- For jointing and rebating on stationary machines

Workpiece material:

- Solid wood and panel materials

Machine:

- Spindle moulders

Scope of supply:

- Tool body including cutters
- Magnetic assembly jig
- Key with handle Torx 25
- Key with handle Torx 20

Special features:

- Spurs fitted top and bottom
- Suitable for rebate and groove milling

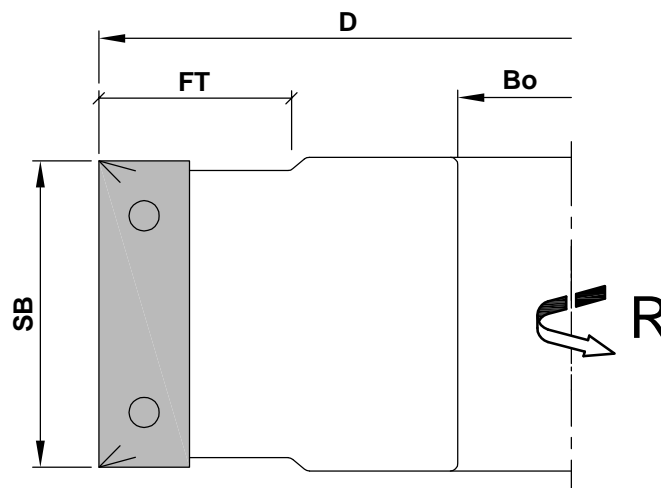
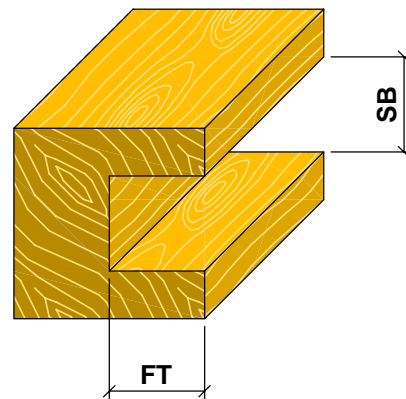
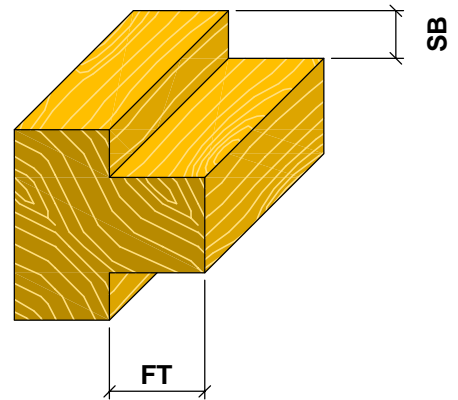

D	SB	FT	Bo	Z	V	R/L	DZ	Ident-No.
100	25.5	18	30	2	2+2	R	7500-13500	C410-100255
125	25.5	25.5	30	2	2+2	R	6000-10000	C410-125255
140	25.5	33	30	2	2+2	R	5500-9500	C410-140255
100	30.5	18	30	2	2+2	R	7500-13500	C410-100305
125	30.5	25.5	30	2	2+2	R	6000-10000	C410-125305
140	30.5	33	30	2	2+2	R	5500-9500	C410-140305
100	40.5	18	30	2	2+2	R	7500-13500	C410-100405
125	40.5	25.5	30	2	2+2	R	6000-10000	C410-125405
140	40.5	33	30	2	2+2	R	5500-9500	C410-140405
100	50.5	18	30	2	2+2	R	7500-13500	C410-100505
125	50.5	25.5	30	2	2+2	R	6000-10000	C410-125505
140	50.5	33	30	2	2+2	R	5500-9500	C410-140505
125	31.0	25.5	30	2+2	2+2	R	6000-10000	C410-125310-WZ
140	31.0	33	30	2+2	2+2	R	5500-9500	C410-140310-WZ
125	41.0	25.5	30	2+2	2+2	R	6000-10000	C410-125410-WZ
140	41.0	33	30	2+2	2+2	R	5500-9500	C410-140410-WZ
125	51.0	25.5	30	2+2	2+2	R	6000-10000	C410-125510-WZ
140	51.0	33	30	2+2	2+2	R	5500-9500	C410-140510-WZ
125	61.0	25.5	30	2+2	2+2	R	6000-10000	C410-125610-WZ
140	61.0	33	30	2+2	2+2	R	5500-9500	C410-140610-WZ

Spare Parts				
Description	Qty.	Dimensions	MBM	Ident-No.
Replacement cutter for SB 25.5	2	25x12x1.5	10	WMF25x12/U
Replacement cutter for SB 30.5	2	30x12x1.5	10	WMF30x12/U
Replacement cutter for SB 31.0	2+2	30x12x1.5	10	WMF30x12/U
Replacement cutter for SB 40.5	2	40x12x1.5	10	WMF40x12/U
Replacement cutter for SB 41.5	2+2	40x12x1.5	10	WMF40x12/U
Replacement cutter for SB 50.5	2	50x12x1.5	10	WMF50x12/U
Replacement cutter for SB 51.0	2+2	50x12x1.5	10	WMF50x12/U
Replacement cutter for SB 61.0	2+2	60x12x1.5	10	WMF60x12/U
Spur for all SBs	4	14x14x2.0	10	VS14x14x2.0/U
Screw Main Cutter		Grub Screw T25 M8x10	10	KW.44253.5
Screw Spur	4	Countersunk Screw M6x10	10	KW.33767.4-10

 e-mail:office@aigner-werkzeuge.at www.aigner-werkzeuge.at	Z.....No. of teeth	Blattformat: A4	All dimensions in mm
	V.....Spur	Zchnng.-Nr. KW.44100.4	
DZ.....Speed Range (rpm)	C410-1		
MBM.....Minimum Order Quantity			