

DP-Shank-Cutter for Clockwise and Counterclockwise-Cutting C340

Cutting Material
DP

Number of Teeth
Z3+Z1

Feed
MEC

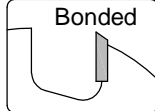

Design:

- Tool body in steel
- Clockwise and counterclockwise in one tool
- Clockwise: Z3, counterclockwise: Z1
- TC boring cutter
- Shank fit h6

Application:

- Grooving and sizing (cutting off)
- Tear-out free machining of workpieces with finish-coated narrow sides
- For protective milling in counterclockwise rotation without a tool change

Workpiece Material:

- Panel materials

Machine:

- CNC machining centres

Scope of Supply:

- Principally with a length adjustment screw; With use in shrink chuck HSK-F 63 (C915) without a length adjusting screw
- Optionally also assembled (and balanced) (MS):
Assembled in shrink chuck HSK-F 63 (C915): C340-....-M1
Assembled in collet chuck HSK-F 63 (C910): C340-....-M2

Special Features:

- Can be used in clockwise and counterclockwise rotation

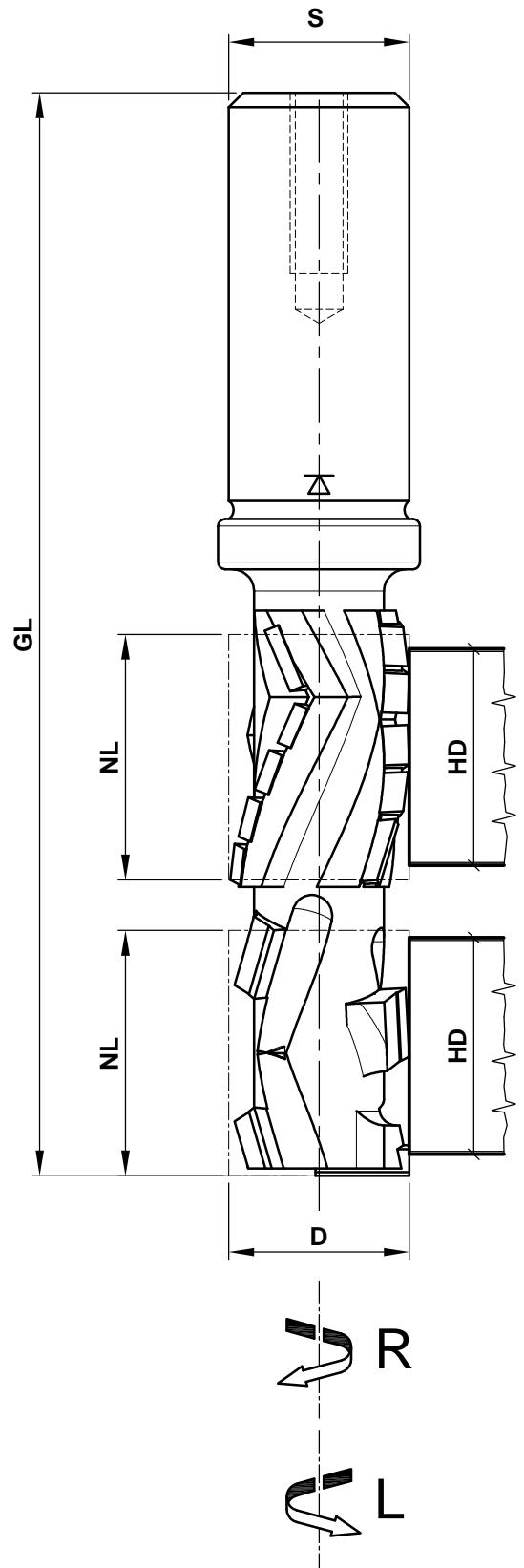

| D | NL | GL | S | Z | R/L | n max. | Ident-No. |
|----|----|-----|----|-----|-----|--------|-----------|
| 25 | 34 | 150 | 25 | 3+1 | R | 25000 | C340-2534 |

Aigner
WERKZEUGE
e-mail:office@aigner-werkzeuge.at
www.aigner-werkzeuge.at

MS.....Machine Adaptor
Z.....No. of Teeth
n max.....Max. Speed (rpm)

Blattformat: **A4** All dimensions in mm
Zchnng.-Nr. KW.43400.4 | 00
C340