

TC-Through-Hole-Borer

C275

Cutting Material
TC

Number of Teeth
Z 2

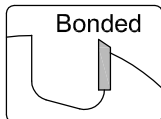

Design:

- Permanently TC tipped with a V-shaped point and double bevel
- Without back guide (guide bevel)
- for tool $\varnothing 3 + \varnothing 4$ spiral part in solid TC, with a V-shaped point in full angle 60° and with back guide

Application:

- Production of through holes

Workpiece material:

- Solid wood and panel materials

Machine:

- Through-feed boring machines, machining centres and special boring machines

Scope of supply:

- Borer assembled with length setting screw Grub screw ISO 7434
- Setting screw special design for Weeke quick-action borer chucks optionally available

Special features:

- Production of tear-free through holes

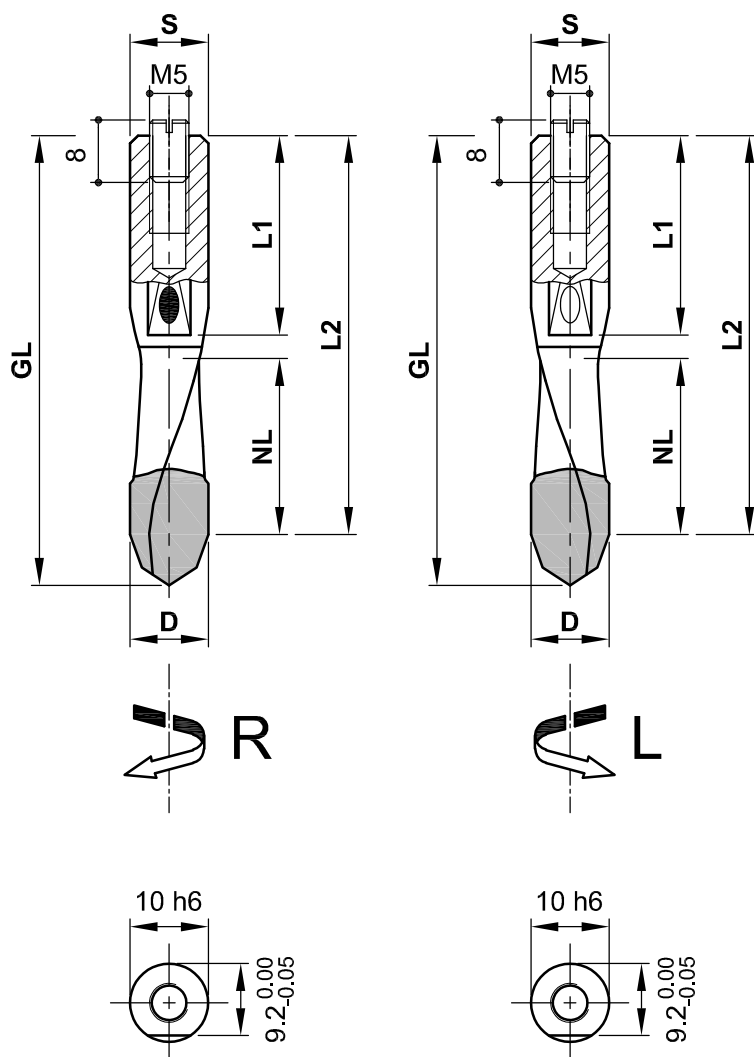

D	NL	GL	L1	L2	S	Z	R/L	DZ	Ident-No.
3	22.5	57.5	27	55.5	10	2	R	3000-9000	C275-03575R
3	22.5	57.5	27	55.5	10	2	L	3000-9000	C275-03575L
4	22.5	57.5	27	54.5	10	2	R	3000-9000	C275-04575R
4	22.5	57.5	27	54.5	10	2	L	3000-9000	C275-04575L
5	22.5	57.5	27	53.5	10	2	R	3000-9000	C275-05575R
5	22.5	57.5	27	53.5	10	2	L	3000-9000	C275-05575L
6	22.5	57.5	27	52.5	10	2	R	3000-9000	C275-06575R
6	22.5	57.5	27	52.5	10	2	L	3000-9000	C275-06575L
8	22.5	57.5	27	51.3	10	2	R	3000-9000	C275-08575R
8	22.5	57.5	27	51.3	10	2	L	3000-9000	C275-08575L
10	22.5	57.5	25.5	51	10	2	R	3000-9000	C275-10575R
10	22.5	57.5	25.5	51	10	2	L	3000-9000	C275-10575L
12	22.5	57.5	25	51.5	10	2	R	3000-9000	C275-12575R
12	22.5	57.5	25	51.5	10	2	L	3000-9000	C275-12575L

optionally

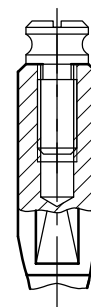

Spare Parts				
Description	Qty.	Dimensions	MBM	Ident-No.
Length Setting Screw Grub, Screw ISO 7434	1	M5x8	10	KW.45451.5
Setting Screw Special Design	1	M5x17	1	KW.44890.5

Aigner
WERKZEUGE
e-mail: office@aigner-werkzeuge.at
www.aigner-werkzeuge.at

Z.....No. of teeth
DZ.....Speed Range (rpm)
MBM.....Minimum Order Quantity

Blattformat: **A4** All dimensions in mm
Zchnng.-Nr. KW.42750.4 00

C275-GL57

TC-Through-Hole-Borer

C275

Cutting Material
TC

Number of Teeth
Z 2

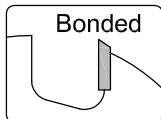

Design:

- Permanently TC tipped with a V-shaped point and double bevel
- Without back guide (guide bevel)
- for tool $\varnothing 3 + \varnothing 4$ spiral part in solid TC, with a V-shaped point in full angle 60° and with back guide

Application:

- Production of through holes

Workpiece material:

- Solid wood and panel materials

Machine:

- Through-feed boring machines, machining centres and special boring machines

Scope of supply:

- Borer assembled with length setting screw Grub screw ISO 7434
- Setting screw special design for Weeke quick-action borer chucks optionally available

Special features:

- Production of tear-free through holes

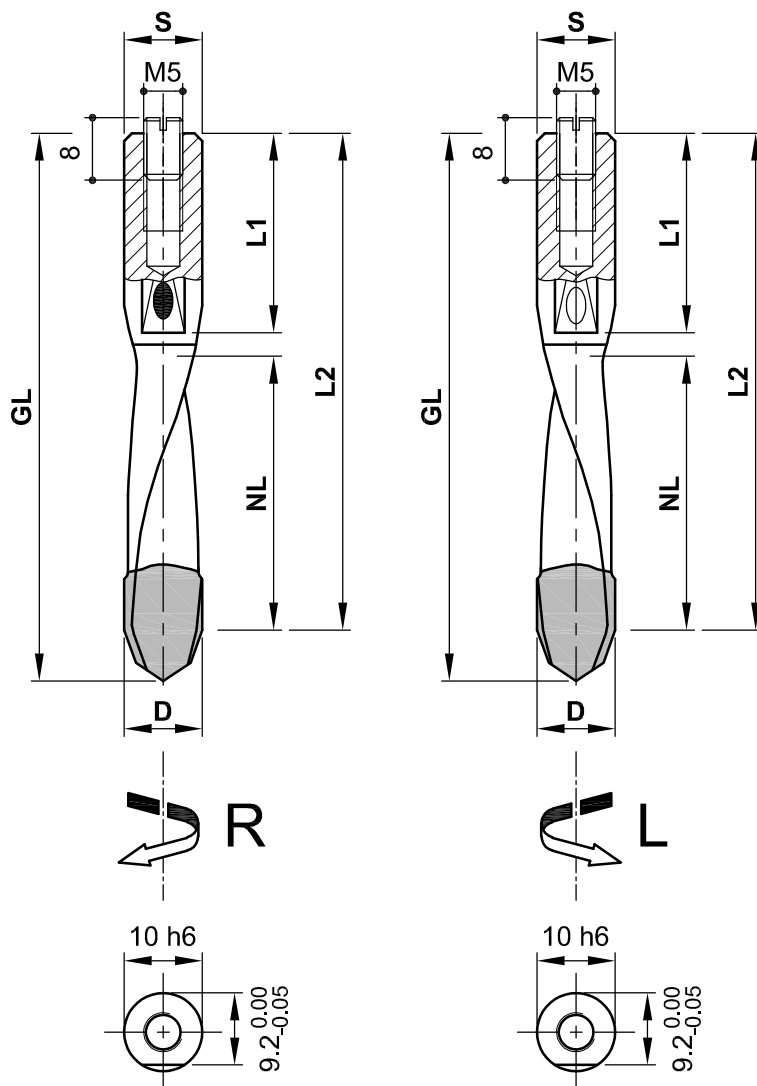

D	NL	GL	L1	L2	S	Z	R/L	DZ	Ident-No.
3	22.5	70	27	68	10	2	R	3000-9000	C275-03700R
3	22.5	70	27	68	10	2	L	3000-9000	C275-03700L
4	35	70	27	67	10	2	R	3000-9000	C275-04700R
4	35	70	27	67	10	2	L	3000-9000	C275-04700L
5	35	70	27	66	10	2	R	3000-9000	C275-05700R
5	35	70	27	66	10	2	L	3000-9000	C275-05700L
6	35	70	27	65	10	2	R	3000-9000	C275-06700R
6	35	70	27	65	10	2	L	3000-9000	C275-06700L
8	35	70	27	64	10	2	R	3000-9000	C275-08700R
8	35	70	27	64	10	2	L	3000-9000	C275-08700L
10	35	70	25.5	63.8	10	2	R	3000-9000	C275-10700R
10	35	70	25.5	63.8	10	2	L	3000-9000	C275-10700L
12	35	70	25	63.5	10	2	R	3000-9000	C275-12700R
12	35	70	25	63.5	10	2	L	3000-9000	C275-12700L

optionally

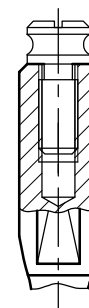

Spare Parts				
Description	Qty.	Dimensions	MBM	Ident-No.
Length Setting Screw Grub, Screw ISO 7434	1	M5x8	10	KW.45451.5
Setting Screw Special Design	1	M5x17	1	KW.44890.5

<p>e-mail: office@aigner-werkzeuge.at www.aigner-werkzeuge.at</p>	Z.....No. of teeth DZ.....Speed Range (rpm)	Blattformat: A4 <small>All dimensions in mm</small> Zchn.-Nr. KW.42750.4 00
	MBM.....Minimum Order Quantity	C275-GL70