

Design:

- Permanently TC tipped with centering point and with negative ground spurs
- Without back guide (guide bevel)
- for tool $\varnothing 3 + \varnothing 4$ spiral part in solid TC and with back guide

Application:

- The production of dowel hole and blind hole bores

Workpiece material:

- Solid wood and panel materials

Machine:

- Through-feed boring machines, machining centres and special boring machines

Scope of supply:

- Borer assembled with length setting screw Grub screw ISO 7434
- Setting screw special design for Weeke quick-action borer chucks optionally available

Special features:

- TC quality of the boring head in micrograin design for a long tool life

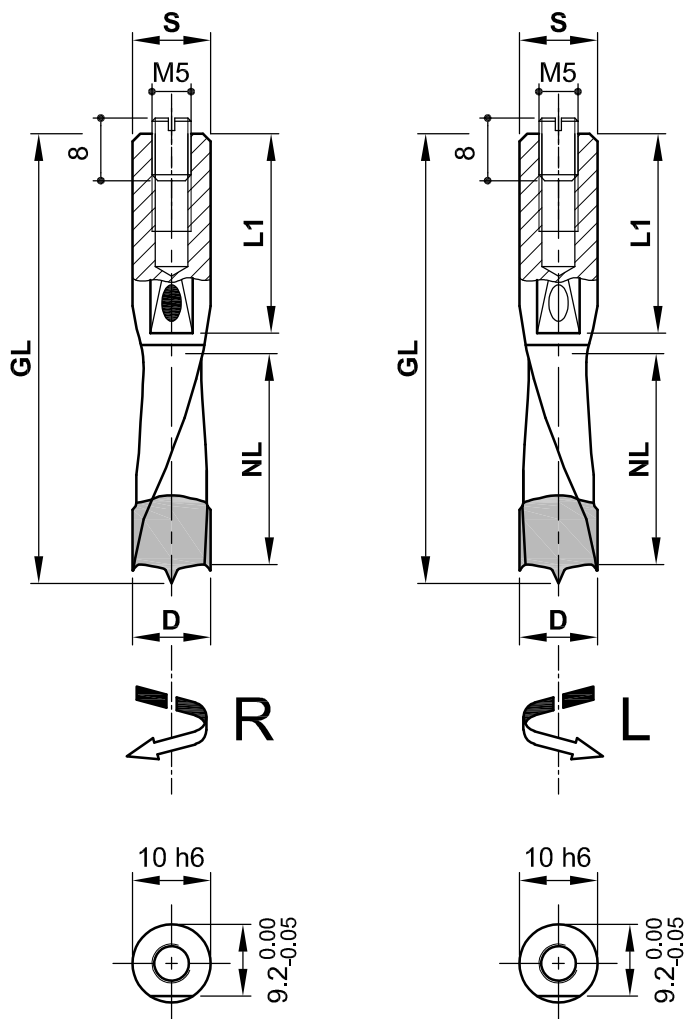

D	NL	GL	L1	S	Z	V	R/L	DZ	Ident-No.
3	23	57.5	27	10	2	2	R	3000-9000	C274-03575R
3	23	57.5	27	10	2	2	L	3000-9000	C274-03575L
4	23	57.5	27	10	2	2	R	3000-9000	C274-04575R
4	23	57.5	27	10	2	2	L	3000-9000	C274-04575L
5	27	57.5	27	10	2	2	R	3000-9000	C274-05575R
5	27	57.5	27	10	2	2	L	3000-9000	C274-05575L
6	27	57.5	27	10	2	2	R	3000-9000	C274-06575R
6	27	57.5	27	10	2	2	L	3000-9000	C274-06575L
8	27	57.5	27	10	2	2	R	3000-9000	C274-08575R
8	27	57.5	27	10	2	2	L	3000-9000	C274-08575L
10	27	57.5	25.5	10	2	2	R	3000-9000	C274-10575R
10	27	57.5	25.5	10	2	2	L	3000-9000	C274-10575L
12	27	57.5	25	10	2	2	R	3000-9000	C274-12575R
12	27	57.5	25	10	2	2	L	3000-9000	C274-12575L

optionally

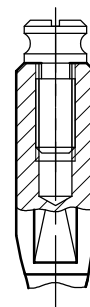

Spare Parts

Description	Qty.	Dimensions	MBM	Ident-No.
Length Setting Screw Grub, Screw ISO 7434	1	M5x8	10	KW.45451.5
Setting Screw Special Design	1	M5x17	1	KW.44890.5

Aigner
WERKZEUGE
e-mail: office@aigner-werkzeuge.at
www.aigner-werkzeuge.at

Z.....No. of teeth
V.....Spur
DZ.....Speed Range (rpm)
MBM.....Minimum Order Quantity

Blattformat: **A4** All dimensions in mm
Zchnng.-Nr. KW.42740.4 | 00

C274-GL57

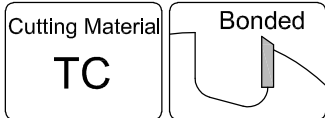

Design:

- Permanently TC tipped with centering point and with negative ground spurs
- Without back guide (guide bevel)
- for tool Ø3 + Ø4 spiral part in solid TC and with back guide

Application:

- The production of dowel hole and blind hole bores

Workpiece material:

- Solid wood and panel materials

Machine:

- Through-feed boring machines, machining centres and special boring machines

Scope of supply:

- Borer assembled with length setting screw Grub screw ISO 7434
- Setting screw special design for Weeke quick-action borer chucks optionally available

Special features:

- TC quality of the boring head in micrograin design for a long tool life

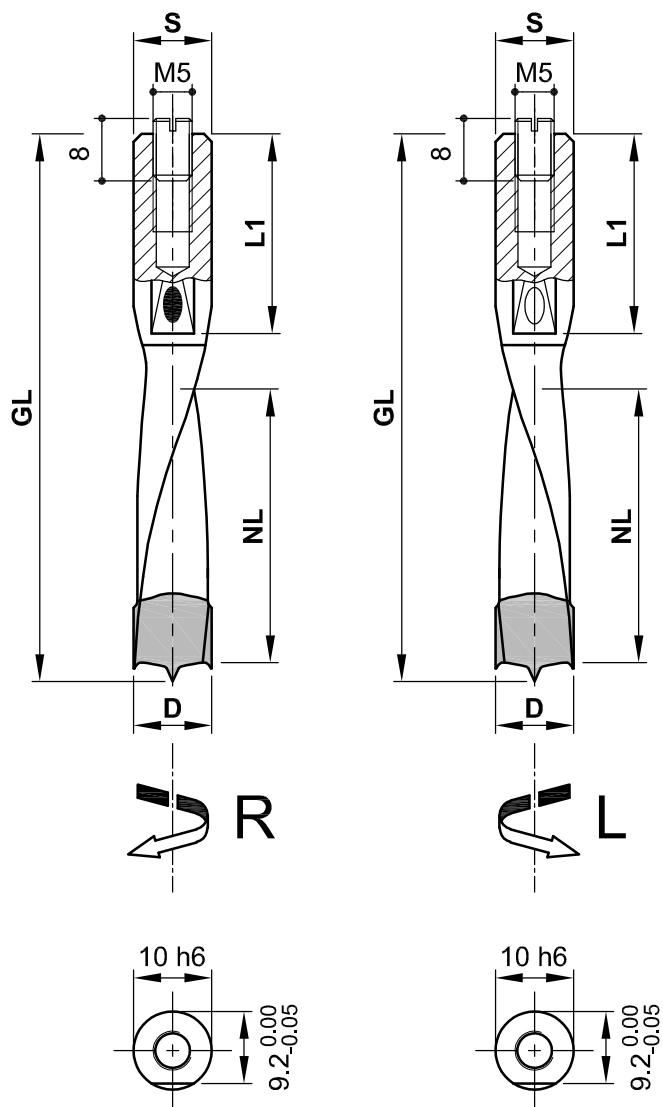

D	NL	GL	L1	S	Z	V	R/L	DZ	Ident-No.
3	23	70	27	10	2	2	R	3000-9000	C274-03700R
3	23	70	27	10	2	2	L	3000-9000	C274-03700L
4	35	70	27	10	2	2	R	3000-9000	C274-04700R
4	35	70	27	10	2	2	L	3000-9000	C274-04700L
5	35	70	27	10	2	2	R	3000-9000	C274-05700R
5	35	70	27	10	2	2	L	3000-9000	C274-05700L
6	35	70	27	10	2	2	R	3000-9000	C274-06700R
6	35	70	27	10	2	2	L	3000-9000	C274-06700L
8	35	70	27	10	2	2	R	3000-9000	C274-08700R
8	35	70	27	10	2	2	L	3000-9000	C274-08700L
10	35	70	25.5	10	2	2	R	3000-9000	C274-10700R
10	35	70	25.5	10	2	2	L	3000-9000	C274-10700L
12	35	70	25	10	2	2	R	3000-9000	C274-12700R
12	35	70	25	10	2	2	L	3000-9000	C274-12700L

optionally

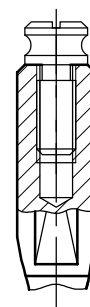

Spare Parts				
Description	Qty.	Dimensions	MBM	Ident-No.
Length Setting Screw Grub, Screw ISO 7434	1	M5x8	10	KW.45451.5
Setting Screw Special Design	1	M5x17	1	KW.44890.5

Aigner
WERKZEUGE
e-mail:office@aigner-werkzeuge.at
www.aigner-werkzeuge.at

Z.....No. of teeth
V.....Spur
DZ.....Speed Range (rpm)
MBM.....Minimum Order Quantity

Blattformat: **A4** All dimensions in mm
Zchnng.-Nr. KW.42740.4 | 00

C274-GL70