

DP-Shank-Grooving-Cutter "Konstantin®-Mini-Finish"

C248

Cutting Material DP	Number of Teeth Z1+1	Feed MEC
-------------------------------	--------------------------------	--------------------

Design:

- Body in steel; with DP plunging cutters
- Z1 + 1 in three chip grooves; with axial angle
- Cutting elements fitted with DP (DIA)
- Shank grooving cutter with replaceable DP cutters
- Deep chip flutes for better chip capture
- Shank fit h6

Application:

- Grooving, jointing, rebating, sizing (cutting off)

Workpiece Material:

- Panel materials: especially melamine-coated and veneered particleboard, MDF, multiplex and plywoods

Machine:

- CNC machining centres

Scope of Supply:

- Principally with a length adjustment screw
With use in shrink chuck HSK-F 63 (C915)
without a length adjusting screw
- Optionally also assembled (MS):
Assembled in shrink chuck HSK-F 63 (C915): C248-...-M1
Assembled in collet chuck HSK-F 63 (C910): C248-...-M2
- Tool body incl. DP knives
- Key with handle Torx T10

Special Features:

- Diameter-constant shank grooving cutter
- All knives replaceable on site
- Suitable for 5-axis machining centres that have no possibility for radius correction when "line milling"
- Very good chip removal
- for increased demands on the milling quality for melamine and HPL coated board materials
- for layer and ply materials with a tendency to tear out
- three different cutter types are mounted for best cutting quality

Additional Information:

- A torque wrench is recommended for the changing of the knives (see C986-FT1810)

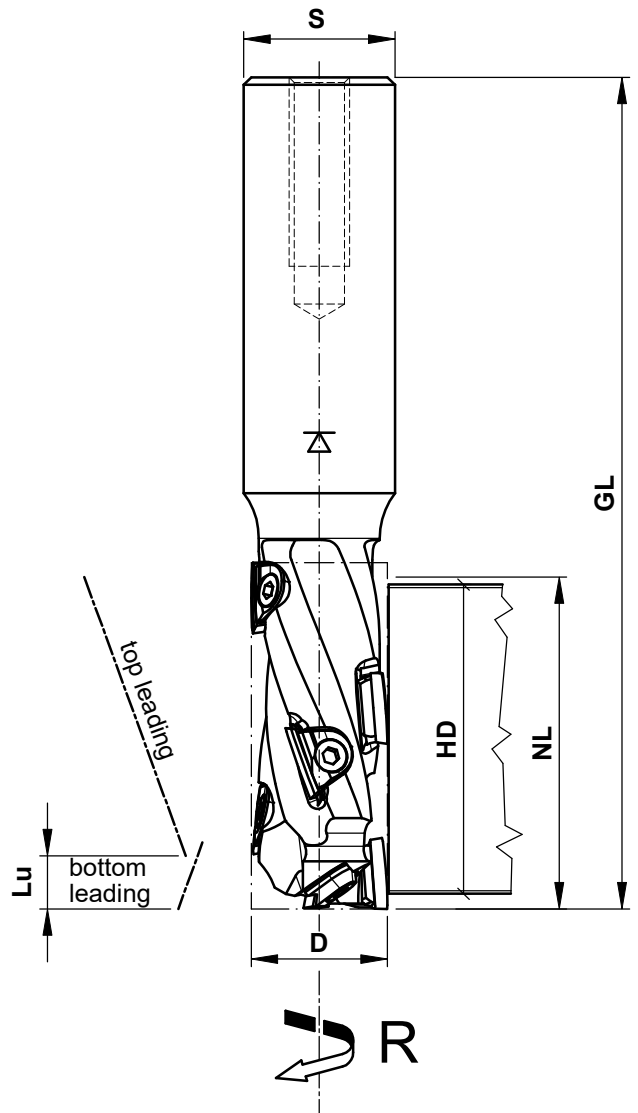

Running plunging

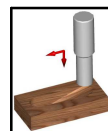

Circular plunging



Aigner
WERKZEUGE

e-mail: office@aigner-werkzeuge.at
www.aigner-werkzeuge.at

MS.....Machine Adaptor

Blattformat: **A4** All dimensions in mm

Zchnng.-Nr. KW.42480.4 | 00

C248

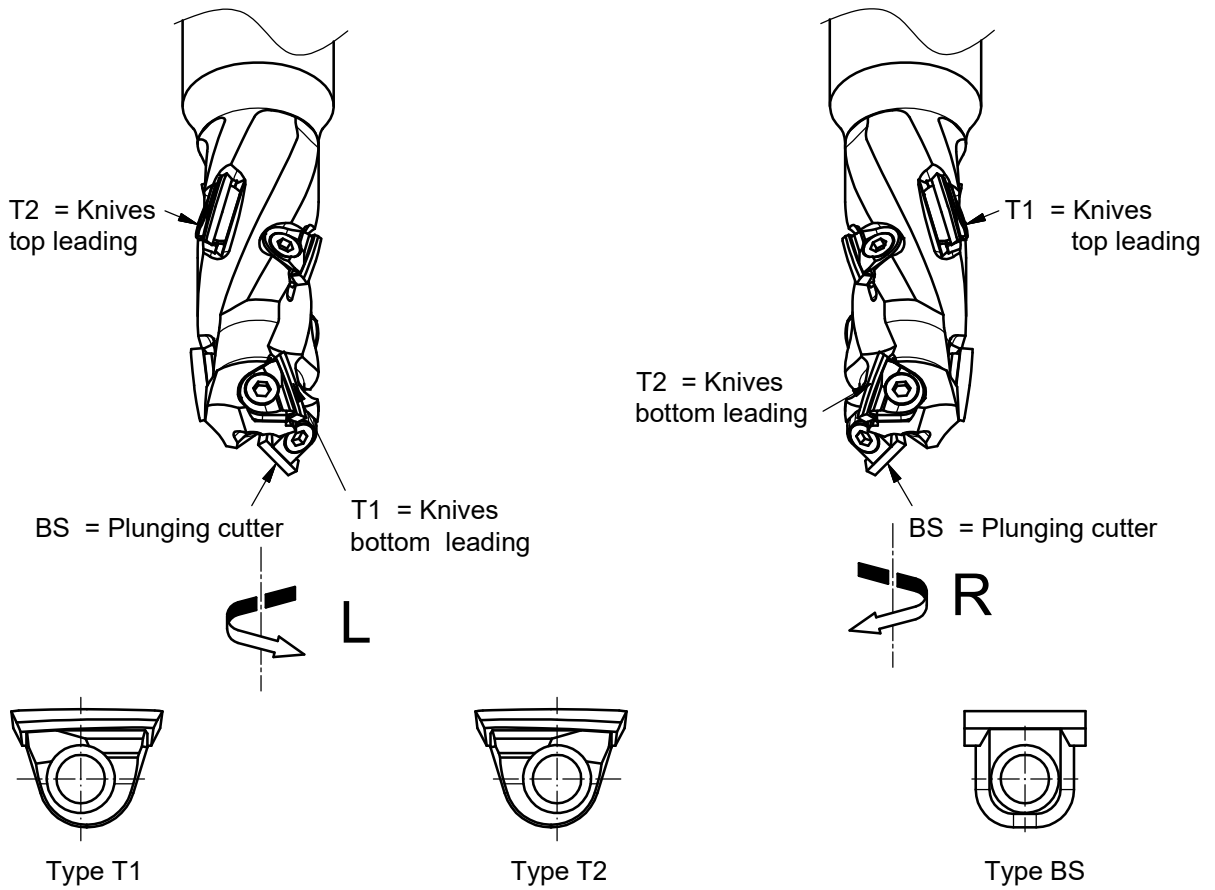

D	NL	GL	Lu	HD	S	Z	R/L	n max.	Ident-No.
16	31.2	95	7	28	20	1x4+1Q	R	24000	C248-1631220R
16	31.2	95	7	28	20	1x4+1Q	L	24000	C248-1631220L
16	31.2	95	7	28	25	1x4+1Q	R	24000	C248-1631225R
16	31.2	95	7	28	25	1x4+1Q	L	24000	C248-1631225L
16	45.8	110	7	43	20	1x6+1Q	R	24000	C248-1645820R
16	45.8	110	7	43	20	1x6+1Q	L	24000	C248-1645820L
16	45.8	110	7	43	25	1x6+1Q	R	24000	C248-1645825R
16	45.8	110	7	43	25	1x6+1Q	L	24000	C248-1645825L
18	31.2	95	7	28	20	1x4+1Q	R	24000	C248-1831220R
18	31.2	95	7	28	20	1x4+1Q	L	24000	C248-1831220L
18	31.2	95	7	28	25	1x4+1Q	R	24000	C248-1831225R
18	31.2	95	7	28	25	1x4+1Q	L	24000	C248-1831225L
18	45.8	110	7	43	20	1x6+1Q	R	24000	C248-1845820R
18	45.8	110	7	43	20	1x6+1Q	L	24000	C248-1845820L
18	45.8	110	7	43	25	1x6+1Q	R	24000	C248-1845825R
18	45.8	110	7	43	25	1x6+1Q	L	24000	C248-1845825L

Spare Parts				
Description	Qty.	Dimensions	MBM	Ident-No.
Replaceable knife-T1	1	10x8x2.5	2	KW.28188.7/B
Replaceable knife-T2	1	10x8x2.5	2	KW.28187.7/B
Replaceable knife for Ø16-BS	1	10x7x2.5	2	KW.15768.7/B25
Replaceable knife for Ø18-BS	1	8x8x2.5	2	KW.19099.7/B25
Clamping screw	1	Countersunk screw M3x6 T10	10	KW.15714.7

 <p>e-mail:office@aigner-werkzeuge.at www.aigner-werkzeuge.at</p>	MS.....Machine Adaptor	Blattformat: A4 <small>All dimensions in mm</small>
		Zchnng.-Nr. KW.42480.4 01
		C248-1