

# DP-Jointing-Cutter "Konstantin®-Mini" Speedy

C247

Cutting Material <b>DP</b>	Number of Teeth <b>Z2+2</b>	Feed <b>MEC</b>
-------------------------------	--------------------------------	--------------------

**Design:**

- Tool body in steel; with DP plunging cutter
- Z2 + 2
- Cutting elements fitted with DP (DIA)
- Jointing end mill with replaceable DP cutters
- Joining area with 54° axis angle
- Drilling range (plunging cutter and lowest circumference cutter) with standard axle angle
- Different cutters in the drilling and joining area
- Shank h6

**Application:**

- Jointing

**Workpiece Material:**

- Panel materials

**Machine:**

- CNC machining centres

**Scope of Supply:**

- Principally with a length setting screw:  
For use with shrink chucks HSK-F 63 (C915) without a length setting screw
- Also optionally assembled (MS):  
Assembled in shrink chuck HSK-F 63 (C915): C247-...-M1  
Assembled in collet chuck HSK-F 63 (C910): C247-...-M2
- Tool body incl. DP cutters
- Key with handle Torx T10

**Special Features:**

- Diameter constant jointing end mill
- All cutters within the respective areas (drilling range and joining area) are interchangeable
- Cutters can be changed on site
- Very well suited to the sizing and fine jointing of laminated and solid wood
- Due to the large axis angle in the joining area the cutters achieve almost tear-free machining results

**Additional Information:**

- A torque wrench is recommended when changing the cutters (see C986-FT1810)
- In order to significantly increase the tool life of the cutter, pre-machining with another tool (e.g. C244 or C436-M) is recommended for larger chip removal.

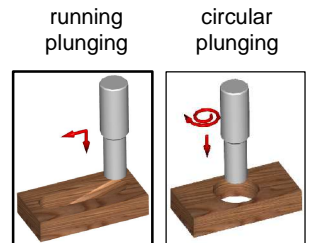
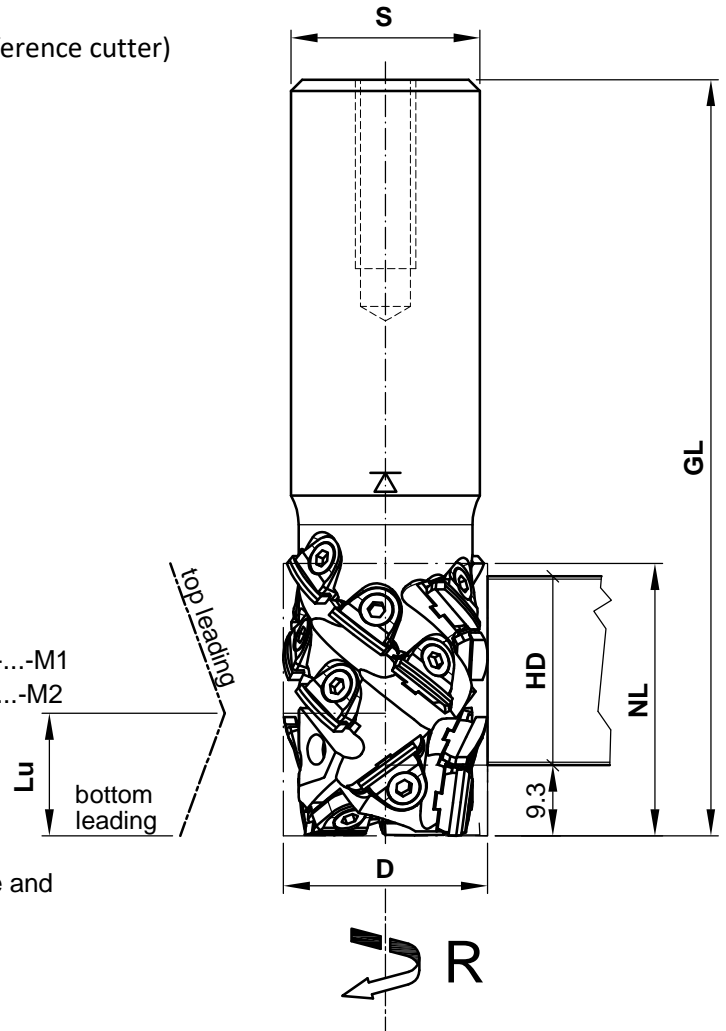

D	NL	GL	Lu	HD	S	Z	R/L	n max.	Ident-No.
27	36	100	16.2	25	25	2x9+2Q	R	24000	C247-273625R
27	53	117	16.2	41	25	2x14+2Q	R	24000	C247-275325R

 e-mail:office@aigner-werkzeuge.at www.aigner-werkzeuge.at	MS.....Machine Adaptor	Blattformat: <b>A4</b>	All dimensions in mm
	Z.....No. of teeth	Zchnng.-Nr. KW.42470.4	
	n max.....Max. Speed (rpm)	<b>C247</b>	

Spare Parts				
Description	Qty.	Dimensions	MBM	Ident-No.
Replaceable cutter circumference cutter	16/26	9x8x2.5	2	KW.23098.7/B02
Replaceable cutter lower circumference cutter	2/2	9x8x2.5	2	KW.22331.7/B25
Replaceable cutter plunging cutter	2/2	9x8x2.5	2	KW.22331.7/B25
Clamping screw	20/30	Countersunk screw M3x6 T10	10	KW.15714.7

 e-mail:office@aigner-werkzeuge.at www.aigner-werkzeuge.at	MBM.....Minimum Order Quantity	Blattformat: <b>A4</b> <small>All dimensions in mm</small>
		Zchnng.-Nr. KW.42470.4   00
		<b>C247-1</b>