

DP-Jointing-Cutter "Konstantin®-Mini" Speedy"

C246

Cutting Material DP	Number of Teeth Z1+1	Feed MEC
-------------------------------	--------------------------------	--------------------

Design:

- Tool body in steel; with DP plunging cutter
- Z1 + 1
- Cutting elements fitted with DP (DIA)
- Jointing end mill with replaceable DP cutters
- Joining area with 54° axis angle
- Drilling range (plunging cutter and lowest circumference cutter) with standard axle angle
- Different cutters in the drilling and joining area
- Shank h6

Application:

- Jointing

Workpiece Material:

- Panel materials

Machine:

- CNC machining centres

Scope of Supply:

- Principally with a length setting screw:
For use with shrink chucks HSK-F 63 (C915) without a length setting screw
- Also optionally assembled (MS):
Assembled in shrink chuck HSK-F 63 (C915): C246-...-M1
Assembled in collet chuck HSK-F 63 (C910): C246-...-M2
- Tool body incl. DP cutters
- Key with handle Torx T10

Special Features:

- Diameter constant jointing end mill
- All cutters within the respective areas (drilling range and joining area) are interchangeable
- Cutters can be changed on site
- Very well suited to the sizing and fine jointing of laminated and solid wood
- Due to the large axis angle in the joining area the cutters achieve almost tear-free machining results

Additional Information:

- A torque wrench is recommended when changing the cutters (see C986-FT1810)
- In order to significantly increase the tool life of the cutter, pre-machining with another tool (e.g. C244 or C436-M) is recommended for larger chip removal.

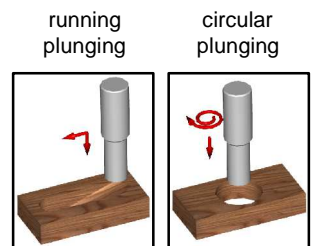
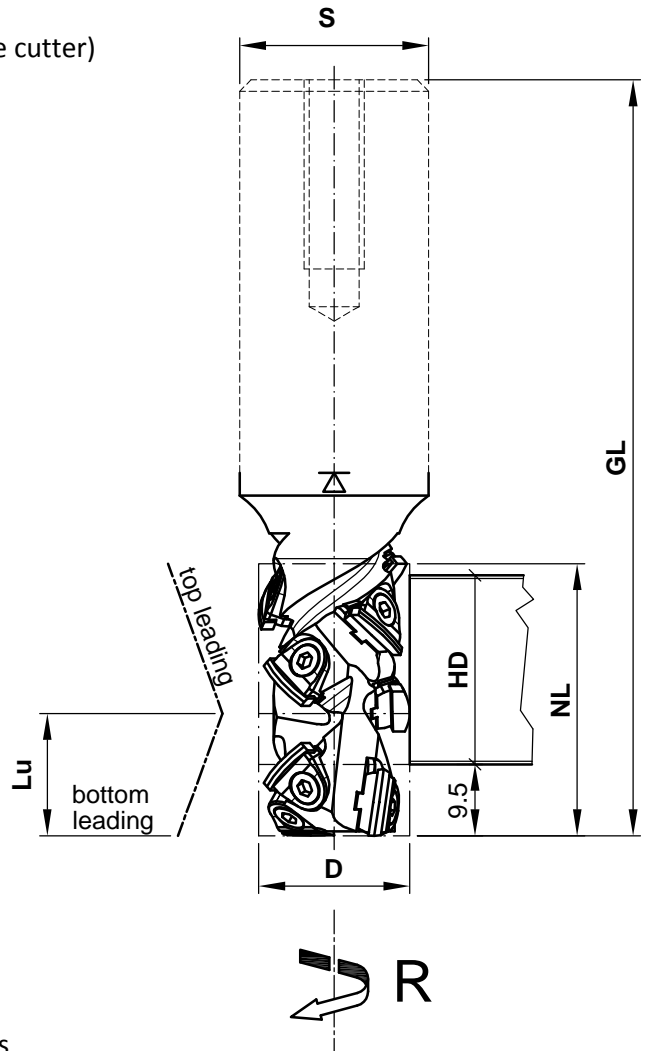

D	NL	GL	Lu	HD	S	Z	R/L	n max.	Ident-No.
20	36	100	16.2	25	25	1x9+1Q	R	24000	C246-203625R
20	60	123.5	16.2	48	25	1x16+1Q	R	24000	C246-206025R

 e-mail:office@aigner-werkzeuge.at www.aigner-werkzeuge.at	MS.....Machine Adaptor	Blattformat: A4	All dimensions in mm
	Z.....No. of teeth	Zchnng.-Nr. KW.42460.4	
	n max.....Max. Speed (rpm)	C246	

DP-Shank-Grooving-Cutter "Konstantin®-Mini" Speedy" C246

Spare Parts				
Description	Qty.	Dimensions	MBM	Ident-No.
Replaceable cutter circumference cutter	8/15	9x8x2.5	2	KW.16728.7/B02
Replaceable cutter lower circumference cutter	1/1	9x8x2.5	2	KW.22331.7/B25
Replaceable cutter plunging cutter	1/1	9x8x2.5	2	KW.22331.7/B25
Clamping screw	10/17	Countersunk screw M3x6 T10	10	KW.15714.7

 e-mail:office@aigner-werkzeuge.at www.aigner-werkzeuge.at	MBM.....Minimum Order Quantity	Blattformat: A4 <small>All dimensions in mm</small>
		Zchnng.-Nr. KW.42460.4 00
		C246-1