

Cutting Material  
**TC**

Number of Teeth  
**Z 2**

Feed  
**MEC**

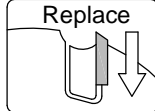

**Design:**

- Tool body in steel
- No. of teeth = 2
- TC profile cutter, drawing cut
- Individual profile design within the maximum profile range

**Application:**

- For the profiling of workpieces

**Workpiece material:**

- Solid wood and panel materials

**Machine:**

- CNC machining centres

**Scope of supply:**

- Tool body including profile knives PM.26688.5/U35 pre-assembled  
If another knife is to be fitted, it must be stated at the time of order. The possible profiles can be seen below.
- Principally with a length adjustment screw; With use in a shrink collet HSK-F 63 (C915) without a length adjustment screw
- Optionally also assembled (and balanced) (MI):  
Assembled in shrink collet HSK-F 63 (C915): C237-....-M1  
Assembled in collet chuck HSK-F 63 (C910): C237-....-M2

**Special features:**

- Various profile available according to customer wishes

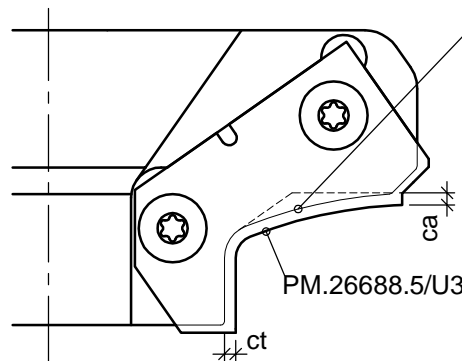
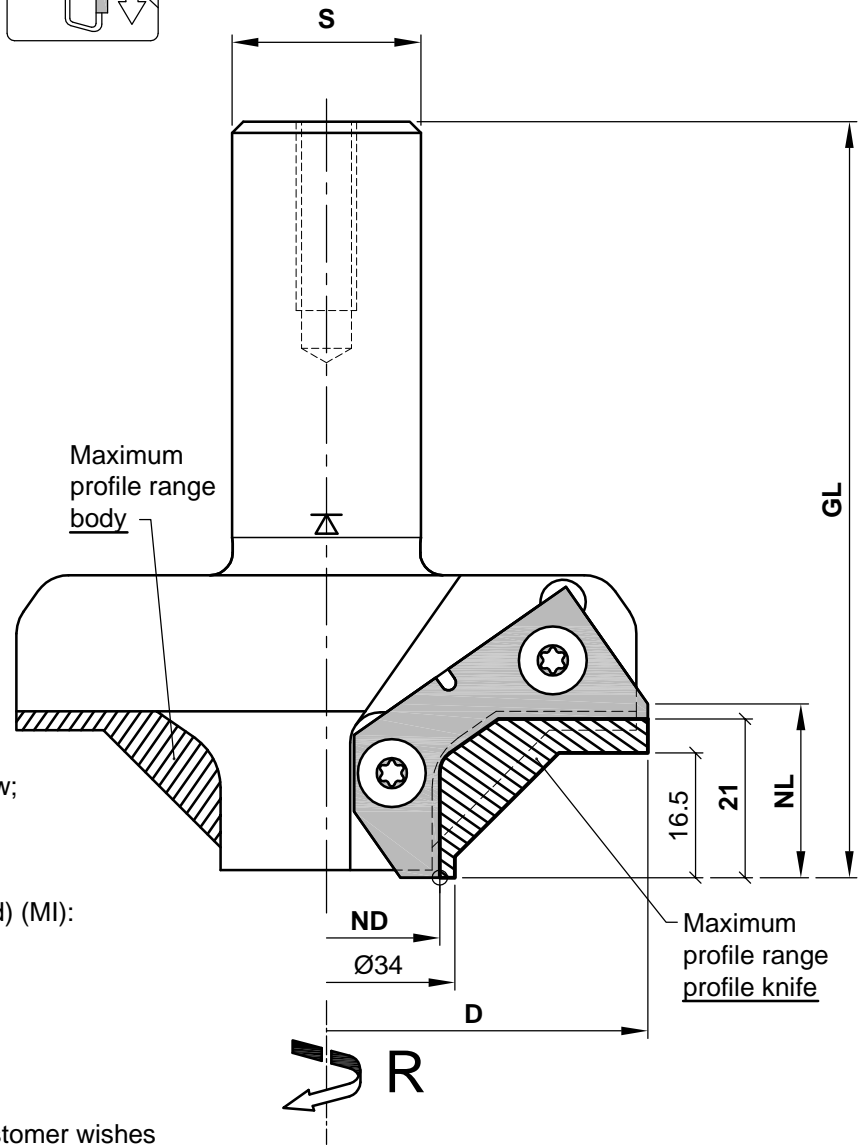

The body is individually manufactured adapted to the desired profile. The use of profile knives with different profiles is only allowed when the maximum cutting edge projections, ca and ct, are each less than 3 mm.

**Profile Examples:**

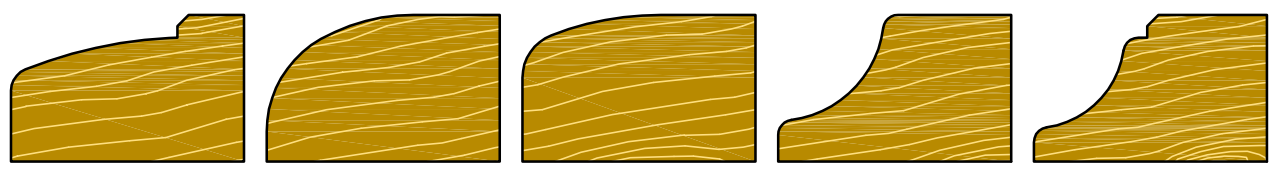

**Aigner**  
WERKZEUGE  
e-mail: office@aigner-werkzeuge.at  
www.aigner-werkzeuge.at

MS.....Machine Adapter

Blattformat: **A4** All dimensions in mm  
Zchnng.-Nr. KW.42370.4 | 00  
**C237**

D	NL	GL	S	Z	R/L	n max.	Ident-No.
85	23	100	20	2	R	18000	C237-8520R
85	23	100	25	2	R	18000	C237-8525R

Spare Parts				
Description	Qty.	Dimensions	MBM	Ident-No.
Profile knives	2	40x25x2	2	PM.26688.5/U35
Roundhead screw	2	M4x6 (head D9) Torx T15	10	KW.44237.5

 <p>e-mail:office@aigner-werkzeuge.at www.aigner-werkzeuge.at</p>	Z.....No. of Teeth	Blattformat: <b>A4</b>	<small>All dimensions in mm</small> Zchnng.-Nr. KW.42370.4   00
	n max.....Max. Speed (rpm)	<h1>C237-1</h1>	
MBM.....Minimum Order Quantity			