

DP-Planing Cutter for CNC

C180

Cutting Material
DP

Number of Teeth
Z 5

Feed
MEC

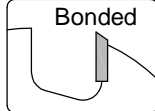

Design:

- Z5
- Shank fit h6
- Positive shear angle (bottom leads)

Application:

- Planing
- For feeds of 12 to 15 m/min

Workpiece material:

- Panel materials

Machine:

- CNC machining centres

Scope of supply:

- Principally with a length setting screw;
For use with shrink chucks HSK-F 63 (C915) without a length setting screw
- Also optionally assembled (and balanced) (MS):
Assembled in shrink chuck
HSK-F 63 (C915): C180-....-M1
Assembled in collet chuck
HSK-F 63 (C910): C180-....-M2

Special features:

- Suitable for the milling on nesting machines of the plane surfaces of cover boards

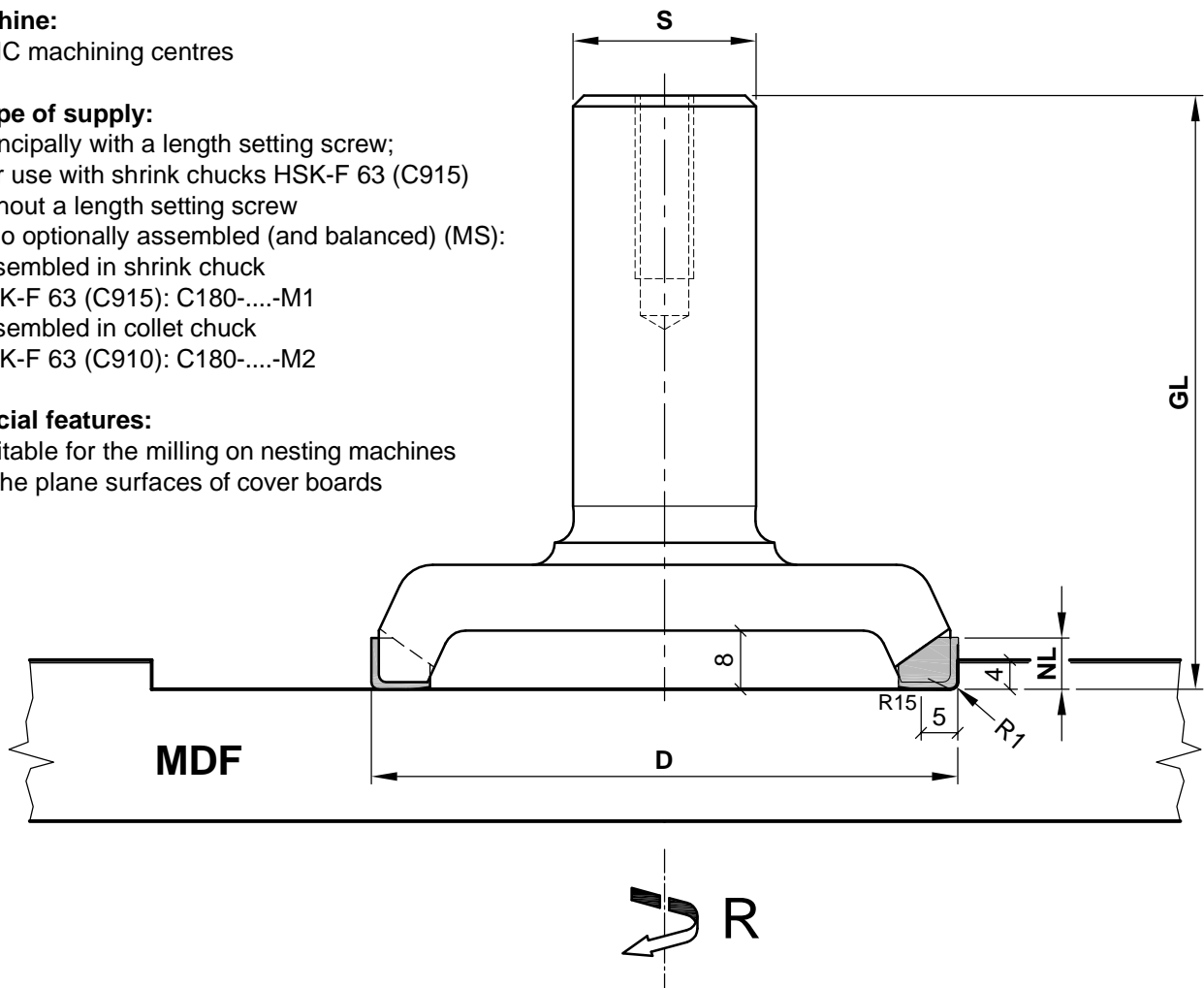

D	NL	GL	S	Z	R/L	n max.	Ident-No.
80	7	81	25	5	R	18000	C180-080725
120	7	81	25	5	R	13000	C180-120725

Aigner
WERKZEUGE
e-mail: office@aigner-werkzeuge.at
www.aigner-werkzeuge.at

MS.....Machine Adaptor
Z.....No. of teeth
n max.....Maximum Rotational Speed (rpm)

Blattformat: **A4** All dimensions in mm
Zchnng.-Nr. KW.41800.4 | 00

C180