

DP-Rebating-Cutter MAN Konstantin®-Mini

C166-5

Cutting Material
DP

Number of
Teeth
Z2+2

Feed
MAN

Design:

- Tool body in steel
- Z2 with top leading cutter
- Cutting elements tipped with DP (DIA)
- Shank cutter with replaceable DP cutters
- Deep chip flutes for better chip capture
- Shank fit h6

Application:

- Rebating cutter with ball bearing

Workpiece material:

- Panel materials

Machine:

- Portable router

Scope of supply:

- Tool body including DP cutter
- Torx handle key T10
- Grooved ball bearing
- Robust twist pack with transparent cover

Special features:

- Constant diameter rebating cutter
- All knives interchangeable
- Knives can be replaced on site
- Very good chip removal
- Ball bearing Ø16/Ø19 interchangeable

Additional Information:

- A torque wrench is recommended for the changing of the knives (see C986-FT1810)

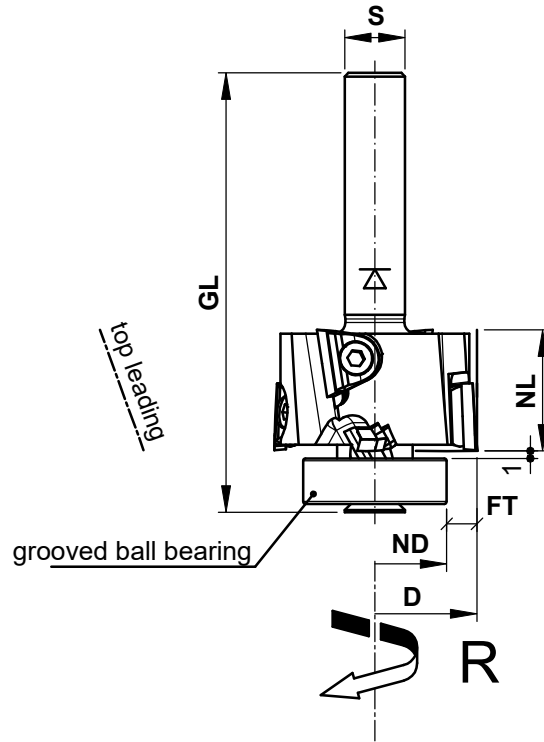

D	ND	NL	FT	GL	S	Z	V	R/L	n max.	Ident-No.
27	19	16	4	58.1	8	2x2+2Q	2	R	22000	C166-5271908R
27	16	16	5.5	57.1	8	2x2+2Q	2	R	22000	C166-5271608R

Spare parts				
Description	Qty.	Dimensions	MBM	Article no.
Replaceable circumference knife	4	9x8x2.5	2	KW.15766.7/B25
Replaceable rebating knife	2	9x8x2.5	2	KW.15766.7/B25
Clamping screw	6	Countersunk screw M3x6 T10	10	KW.15714.7
Grooved ball bearing Ø19	1	19x6x6	1	KW.52987.5
Grooved ball bearing Ø16	1	16x6x5	1	KW.53133.5
Screw for grooved ball bearing	1	Countersunk screw M4x8	10	KW.44317.5

 <p>e-mail:office@aigner-werkzeuge.at www.aigner-werkzeuge.at</p>	Z.....No. of teeth	Blattformat: A4 <small>dimensions in mm</small>
	V.....Spur	Zchnng.-Nr. KW.41665.4 00
n max.....Maximal rotational speed (rpm)	<h1>C166-5</h1>	
MBM.....Minimum order quantity		